

CYBIF • Cylindrical Bifurcated Axial Fans



Specification

- CYBIF Cylindrical inline axial flow bifurcated fan manufactured from pre-galvanised sheet steel.
- Fan incorporates inlet and outlet flanges with pre-drilled bolt holes.
- The motor is totally enclosed fan cooled and protected to IP55.
- Foot mounted B3 class F insulated.
- Sealed for life ball bearings.
- The fan impeller blades are manufactured from either injection moulded glass re-enforced polypropylene or glass.
- Re-enforced polyamide depending on fan size. The hub in all cases is die cast aluminium alloy as standard.
- Optional extra. eeXD Group 11B T4 motors and other special motors can be incorporated into this range.
- Optional extra. Aluminium and anti-static type impellers are available and can be incorporated into this range of fans.
- These options will enable the fan to handle potentially dangerous and hazardous atmospheres such as cellulose paint fume and battery charging fumes. Please contact our sales department for advice on any application.

Features

- Up to 17.5 m³/sec performance.
- 9 models to choose from.
- Heavy gauge galvanised steel construction.
- Suitable for internal and external applications at any installed angle.
- Wide range of ancillaries available.
- Suitable for a wide range of applications and high temperatures.
- Motor out of air stream enabling the fan to handle fumes and atmospheres that would otherwise damage the motor.
- Matching attenuators and a wide range of installation ancillaries.
- Fan diameters compatible with standard spiral ducting.

CYBIF • Cylindrical Bifurcated Axial Fans. Manufactured from heavy gauge galvanised sheet steel.

CYBIF Fans

The Cylindrical bifurcated axial flow range of fans consists of 9 duty sizes with a maximum air flow of 17.5 m³/s. The units are manufactured from galvanised sheet steel to BS. 2989. 1982. All units are suitable for internal and external applications at any installed angle.

Handling

Always handle the units carefully to avoid damage and distortion. Care must be taken to ensure that any slings used for hoisting do not damage the casing or fan impeller.

Fan installation

Installation must be completed by competent persons, in accordance with good industry practice and should conform to all governing and statutory bodies i.e. IEE, CIBSE, COHSE etc. The unit can be installed at any angle and is suitable for internal or external use. Ensure that the air flows over the impeller before the motor. The unit is flanged at both ends and can be connected to the system by either bolting directly to the ducting or via flexible connections [optional extra]. Optional mounting feet and anti vibration mounts are available. The method chosen is the responsibility of the installer.

Electrical

Check that the fan details on the rating plate correspond with the supply voltage and frequency. Motors up to 4.0 Kw are designed for Direct on Line starting. Motors 5.5kw and above should be star/delta started. Motor overloads should be set to the full load current on the fan rating label. Supply fuses should be H.R.C. type.

Start-up procedure

Note! The single phase rotational direction is set at works and should NOT be altered. For three phase units check that rotation is correct, if not interchange two phases. [Refer to rotation arrows on outside of fan case]. Equipment should be run for approximately 30 minutes to ensure correct operation. If a fault occurs, switch off. DO NOT restart until fault has been rectified.

CONNECTION DIAGRAM FOR SINGLE PHASE MOTORS.

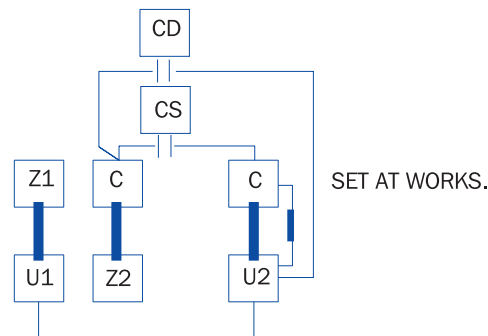

CONNECTION DIAGRAM FOR 3 PHASE MOTORS. 415 volts. 3 phase. 50 hz supply

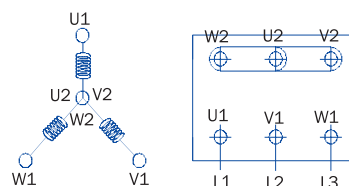

STAR CONNECTION FOR 415 volts up to 3.0 kw

A STAR CONNECTION IS OBTAINED BY CONNECTING W2, U2, V2, TERMINALS TO EACH OTHER AND THE U1, V1, W1 TERMINALS TO THE MAINS.

Motor / Fan details

Unit	Phase	Kw	flc	sc	rpm	max temp	A dia	B	Kg
CYBIF-400-41	1	0.37	3.40	10.0	1400	80c	400	590	
CYBIF-400-21	1	2.2	13.7	65.0	2800	80c	400	590	
CYBIF-500-41	1	1.1	7.30	40.0	1400	80c	500	670	
CYBIF-560-41	1	1.5	10.0	51.0	1410	80c	560	670	
CYBIF-400-43	3	0.37	0.87	5.22	1400	80c	400	590	
CYBIF-400-23	3	2.2	4.42	30.94	2800	80c	400	590	
CYBIF-500-43	3	1.1	2.52	17.64	1400	80c	500	670	
CYBIF-560-43	3	1.5	3.34	23.38	1410	80c	560	670	
CYBIF-630-43	3	3.0	6.25	43.75	1420	80c	630	670	
CYBIF-710-23	3	4.0	7.98	55.86	1425	80c	710	670	
CYBIF-800-43	3	5.5	10.54	24.59	1450	80c	800	800	
CYBIF-900-43	3	7.5	14.45	33.72	1450	80c	900	800	
CYBIF-1000-43	3	11.0	20.47	47.72	1460	80c	1000	950	

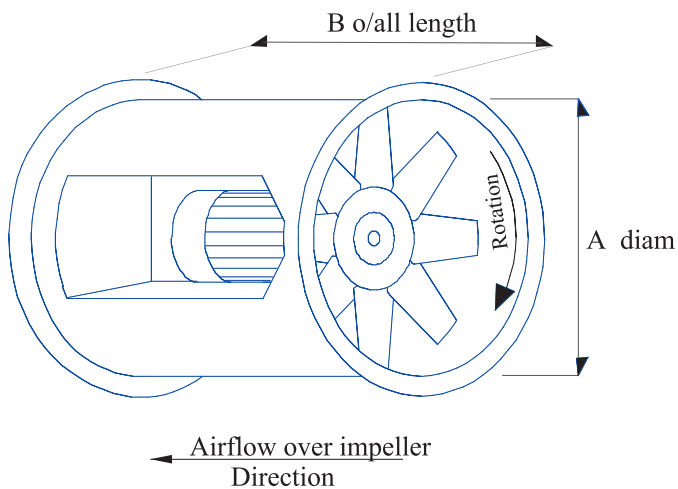

Maintenance

Electrically isolate before commencing work. Remove fan unit from system. Carefully clean rotating parts and check for damage and security of components. The motor is fitted with sealed for life bearings and does not require any further lubrication. Refit fan unit into system.

One year Warranty

The 1 year warranty starts from the day of delivery and includes parts and labour for the first year. This warranty is conditional on maintenance being carried out at the end of the first 3 month period.

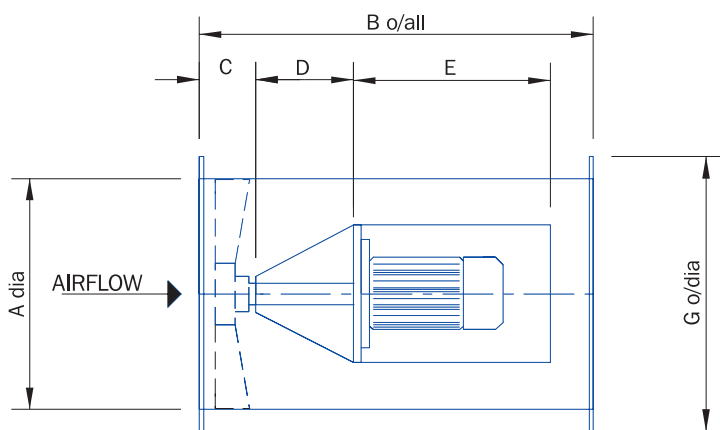

FLANGE DETAIL

H number of I diameter holes on J pcd.

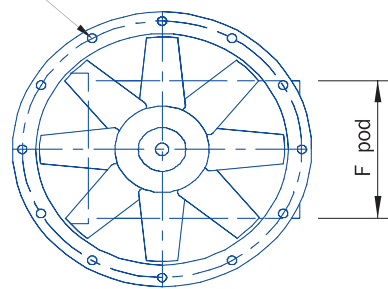

Size	Dimensional Data [mm]										Max motor frame	FAN POWER		MOTOR POWER	
	A	B	C	D	E	F	G	H	I	J		4 POLE	2 POLE	4 POLE	2 POLE
400	400	590	135	100	300	230	486	8	12	450	D90	0.24	1.80	0.37	2.2
500	500	670	140	125	350	305	588	12	12	560	D100	0.85	-----	1.1	-----
560	560	670	140	125	350	305	648	12	12	620	D100	1.25	-----	1.5	-----
630	630	670	140	125	350	305	720	12	12	690	D112	2.15	-----	3.0	-----
710	710	670	140	125	350	305	800	16	12	770	D112	3.10	-----	4.0	-----
800	800	800	155	150	450	360	890	16	12	860	D132	4.90	-----	5.5	-----
900	900	800	155	150	450	360	990	16	15	970	D132	6.50	-----	7.5	-----
1000	1000	950	200	200	450	360	1112	16	15	1070	D160	10.2	-----	11.0	-----

CYBIF • Cylindrical Bifurcated Axial Fans.

Manufactured from heavy gauge galvanised sheet steel.

Technical Data							SOUND POWER LEVELS db OCTAVE BAND MID FREQUENCIES							
FAN CODE	Phase	Rpm Nom'l	Kw	amps. flc	amps. sc	start type	125	250	500	1K	2K	4K	8K	dbA@1m
CYBIF-400-41	1	1400	0.37	3.20	7.83	DOL	74	82	75	73	70	67	64	73
CYBIF-400-21	1	2800	2.2	13.10	56.33	DOL	88	90	95	87	84	81	78	89
CYBIF-500-41	1	1400	1.1	28.08	28.08	DOL	81	89	82	80	77	74	71	81
CYBIF-560-41	1	1410	1.5	39.99	39.99	DOL	84	92	85	83	80	77	74	85
CYBIF-400-43	3	1400	0.37	1.20	4.56	DOL	74	82	75	73	70	67	64	73
CYBIF-400-23	3	2800	2.2	4.70	26.79	DOL	88	90	95	87	84	81	78	89
CYBIF-500-43	3	1400	1.1	2.75	11.27	DOL	81	89	82	80	77	74	71	81
CYBIF-560-43	3	1410	1.5	3.65	16.79	DOL	84	92	85	83	80	77	74	85
CYBIF-630-43	3	1420	3.0	6.80	35.36	DOL	87	95	88	86	83	80	77	88
CYBIF-710-23	3	1425	4.0	8.60	48.16	DOL	95	91	90	88	85	82	79	90
CYBIF-800-43	3	1450	5.5	11.50	23.76	S/D	99	95	94	92	89	86	83	96
CYBIF-900-43	3	1450	7.5	15.20	33.95	S/D	99	95	94	92	89	86	83	96
CYBIF-1000-43	3	1460	11.0	22.50	39.00	S/D	96	104	97	95	92	89	86	99

Performance

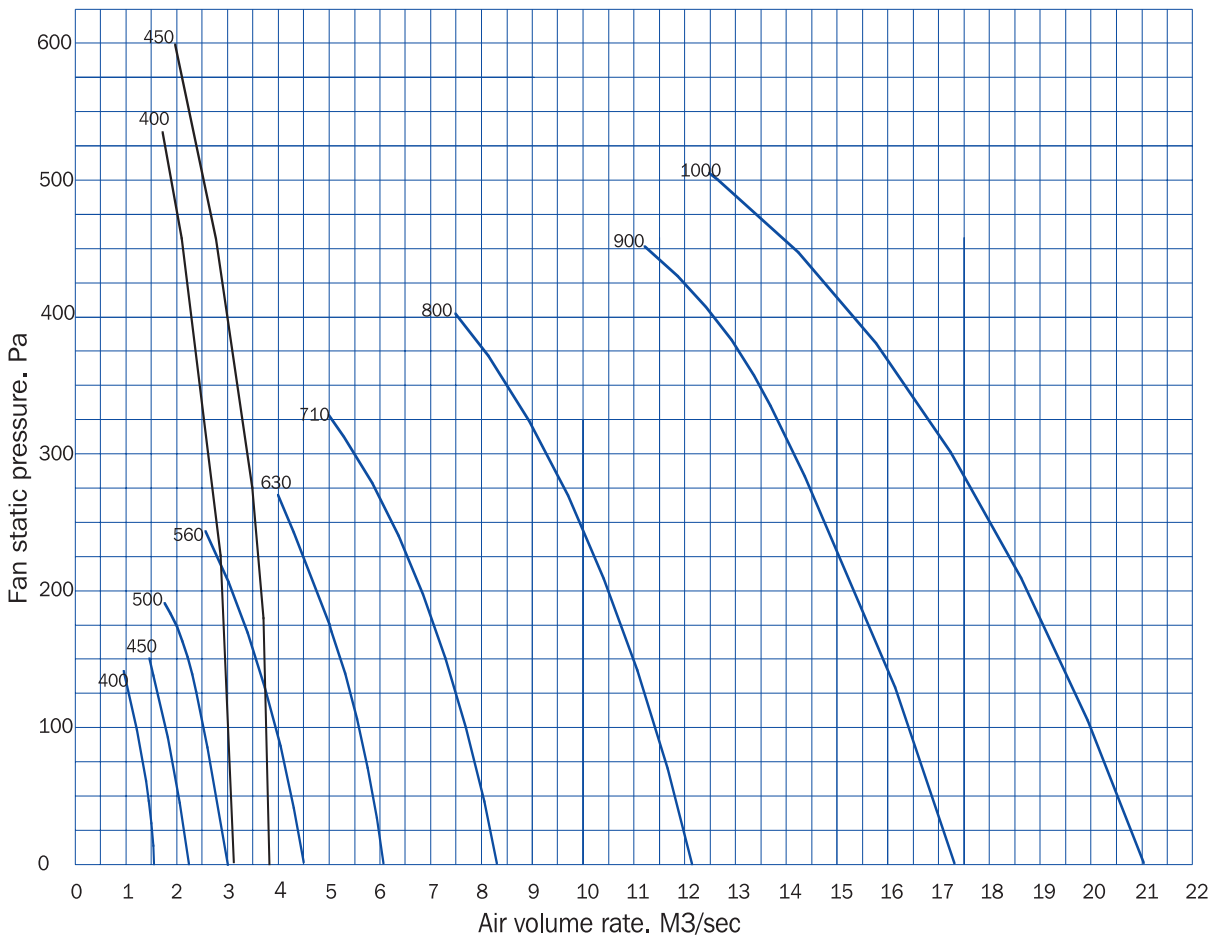

CYLINDRICAL BIFURCATED FAN CURVES. 4/2 POLE VERSION

EC DECLARATION OF INCORPORATION FOR PARTY COMPLETED MACHINERY. (MACHINERY DIRECTIVE 2006/42/EC, ANNEX III.B)

Manufacturer: Moduflow Fan Systems Ltd.
Scarth Road
Sowerby Woods Industrial Estate
Barrow-in-Furness
Cumbria LA14 4RF

Type of Machinery: Fan used for moving air or other gases.

Model: CYLINDRICAL BIFURCATED AXIAL FANS

Manufacturer's Ref / Serial No:

I hereby declare that the Essential Health and Safety Requirements of Directive 2006/42/EC that are listed in Annex 1 of this Declaration are applied and fulfilled and that the relevant technical documentation is compiled in accordance with part B of Annex VII of the Directive.

Relevant information on the party completed machinery will be supplied electronically or by post, without prejudice to the intellectual property rights of the manufacturer, in response to a reasoned request by the national authorities.

I furthermore declare that fans manufactured by Moduflow Fan Systems Ltd. are driven by AC induction motors and are inherently compliant with the requirements of the Electromagnetic Compatibility Directive (2004/108/EEC) if supplied with a truly sinusoidal AC supply. Where the fan motor is supplied via a frequency converter or other electronic control, verification of compatibility together with cabling should be sought from the control supplier.

This partly completed machinery must not be put into service until the final machinery or installation into which it is to be incorporated has been declared in conformity with the provisions of Directive 2006/42/EC, where appropriate.

Manufacturer's Representative: R P Whitworth. Position: Director

Signature: Date:

ANNEX I (EC DECLARATION OF INCORPORATION FOR PARTY COMPLETED MACHINERY)

Essential health and safety requirements relating to the design and construction of the Party Completed Machinery.

The following Essential Health and Safety Requirements of Directive 2006/42/EC Annex 1.1, are applied and fulfilled as appropriate:

- 1.1.3 Materials and products
- 1.1.5 Design of machinery to facilitate its handling
- 1.3.1 Risk of loss of stability
- 1.3.2 Risk of break-up during operation
- 1.3.4 Risk due to surfaces, edges or angles
- 1.3.6 Risk related to variations in operating conditions
- 1.5.1 Risk related to electricity supply
- 1.5.4 Errors of fitting
- 1.5.6 Fire
- 1.5.7 Explosion
- 1.5.9 Vibrations
- 1.5.10 Radiation
- 1.5.11 External radiation
- 1.5.13 Emissions of hazardous materials and substances
- 1.6.4 Operator intervention
- 1.7.1 Information and warnings on the machinery
- 1.7.3 Marking of machinery (as appropriate without CE mark)
- 1.7.4 Instructions
 - 1.7.4.1 General principles for the drafting of instructions
 - 1.7.4.2 Contents of the instructions
 - 1.7.4.3 Sales literature

Presumption of conformity with the above listed EHSRs is by application of relevant parts of the following standards:

Applied harmonized standards in particular:
EN ISO 12100-1:2003+A1:2009, EN ISO 12100-2:2003+A1:2009, EN 60204-1:2006+A1:2009, EN ISO 5801:2008 (BS 848-1:2007).

Applied national standards in particular:
BS 848-2.1:2004 (BS ISO 13347-1:2004), BS 848-6:2003 (BS ISO 14695:2003), BS 848-7:2003 (ISO 14694:2003).

INFORMATION FOR SAFE INSTALLATION, OPERATION AND MAINTENANCE OF MODUFLOW LTD VENTILATION EQUIPMENT

To comply with EC Council Directives 2006/42/EC Machinery Directive.
To be read in conjunction with the relevant Product Documentation [see 2.1]

1.0 GENERAL

1.1 The equipment referred to in this Declaration of Incorporation is supplied by Moduflow Ltd to be assembled into a ventilation system which may or may not include additional components.

The entire system must be considered for safety purposes and it is the responsibility of the installer to ensure that all the equipment is installed in compliance with the manufacturers recommendations and with due regard to current legislation and codes of practice.

2.0 INFORMATION SUPPLIED WITH THE EQUIPMENT

2.1 Each item of equipment is supplied with a set of documents which provides the the information required for safe installation and maintenance of the equipment. This may be in the form of a Data sheet and/or Installation and Maintenance instruction.

2.2 Each unit has a rating plate attached to its outer casing. The rating plate contains essential data relating to the equipment such as serial number, unit code and electrical data. Any further data that may be required will be found in the documentation. If any item is unclear or more information is required, contact Saverfan.

2.3 Where warning labels or notices are attached to the unit, the instructions given must be adhered to.

3.0 TRANSPORTATION, HANDLING AND STORAGE.

3.1 Care must be taken at all times to prevent damage to the equipment. Note that shock to the unit may result in the balance of the impeller being affected.

3.2 When handling the equipment, care should be taken with corners and edges and that the weight distribution within the unit is considered. Lifting gear such as slings or ropes must be arranged so as not to bear on the casing or impeller/motor.

3.3 Equipment stored on site prior to installation should be protected from the weather and steps taken to prevent the ingress of contaminants.

4.0 OPERATIONAL LIMITS

4.1 It is important that the specified operation limits for the equipment are adhered to e.g. operation air temperatures, air borne contaminants and unit operation.

4.2 Where installation accessories are supplied with the specified equipment e.g. wall mounting brackets or anti-vibration mounts, they are to be used to support the equipment only. Other system components must have separate provision for support.

4.3 Flanges and connection spigots are provided for the purpose of joining to ductwork systems. They must not be used to support the ductwork.

5.0 INSTALLATION REQUIREMENTS

In addition to the particular requirements given for the individual product, the following general requirements should be noted.

5.1 Where access to any part of equipment which moves, or can become electrically live are not prevented by the equipment panels or by fixed installation detail [e.g ducting], then guarding to the appropriate standard must be fitted.

5.2 The electrical installation of the equipment must comply with the requirements of the relevant local electrical standards.

6.0 COMMISSIONING REQUIREMENTS

6.1 General pre-commissioning checks relevant to safe operation consist of the following:

Ensure that no foreign bodies are present within the fan or casing.

Check electrical safety, eg. Insulation and earthing.

Check guarding of system.

Check operation of Isolators/controls.

Check fastenings for security.

6.2 Other commissioning requirements are given in the relevant product documentation.

7.0 OPERATIONAL REQUIREMENTS

7.1 Equipment access panels must be in place at all times during operation of the unit and must be secured with the original fastenings.

7.2 If failure of equipment occurs or is suspected then it should be taken out of service until a competent person can effect repair or examination. [Note that certain ranges of equipment are designed to detect and compensate for fan failure].

8.0 MAINTENANCE REQUIREMENTS

8.1 Specific maintenance requirements are given in the relevant documentation.

8.2 It is important that the correct tools are used for the various tasks required.

8.3 If the access panels are to be removed for any reason the electrical supply to the unit must be isolated.

8.4 A minimum period of 2 minutes should be allowed after electrical disconnection before access panels are removed. This will allow the impeller to come to rest.

NB: Care should still be taken however since airflow generated at some other point in the system can cause the impeller to 'windmill'.

8.5 Care should be taken when removing and storing access panels in windy conditions.