

Moduflow Fan Type C



Specification

The Moduflow ranges of variable discharge centrifugal fans are constructed with a rigid 2mm and 1.5mm galvanised steel case. The fan cases are fitted with circular spigot inlets, to accept spiral ducting. The discharge flange is pre-drilled. The fans are fitted with backward curved impellers. All motors are TEFC and have sealed for life bearings and class F insulation.

Ideal for handling light dust applications. Inlet spigots on all fans match standard spiral ducts. Ideal where system resistance is high. All 3 phase and single phase motors are class F insulation IP55 as standard.

Features

- Rigid construction – **robust and durable on site can be used internally or externally**
- 17 models – **wide choice**
- Can be fitted top, bottom, horizontal or vertical – **no need to adjust fan assembly bolts**
- Motor out of air stream – **cleaner operation in greasy environments**
- TEFC motors out of air stream – **suitable for high temperatures**
- 1 or 3 phase versions
- Can be speed controlled
- Cost effectively suits all fan sizes
- Simple wiring – **quick and easy to install**
- Wide range of ancillaries – **av's, flanges, silencers & feet**
- LOW COST

Moduflow Type C Backward Curved High Temperature Fan Product Installation & Maintenance Instructions

Moduflow Type C Fans

The Backward Curved Centrifugal Range of fans consist of 17 duty sizes with a maximum air flow of 55,000 m³/h. The units are manufactured from pre-galvanised sheet steel to BS.2989.1982. All units can be mounted top, bottom, horizontal or vertical discharges without having to adjust the fan assembly bolts.

Handling

Always handle the units carefully to avoid damage and distortion. Care must be taken to ensure that any slings used for hoisting do not damage the casing.

Fan Installation

Installation must be completed by competent persons, in accordance with good Industry practice and should conform to all governing and statutory bodies. ie. IEE, CIBSE, COHSE etc. The unit can be installed at any upward vertical or horizontal position and is suitable for internal or external use. Elongated mounting slots are provided on 3 sides of the unit for either bolting directly to the mounting surface or via anti-vibration mounts. The method chosen is the responsibility of the installer.

Electrical

Check that the fan details on the rating plate correspond with the supply voltage and frequency. Motors are designed for direct on-line starting. Motor overloads should be set to the full load current on the fan rating label. Supply fuses should be H.R.C type.

Start-up Procedure

Note! The single phase rotational direction is set at works and should not be altered. For 3 phase units check that rotation is correct, if not, interchange two phases. Equipment should be run for approximately 30 minutes to ensure correct operation. If a fault occurs, switch off. DO NOT restart until fault has been rectified.

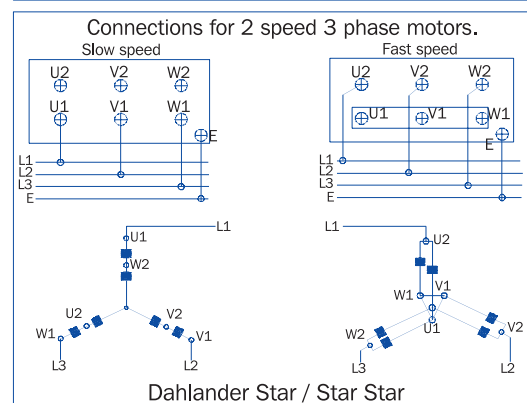
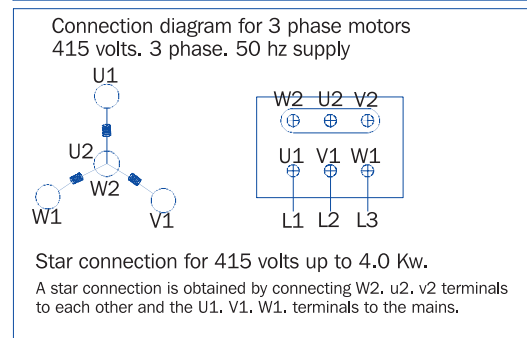
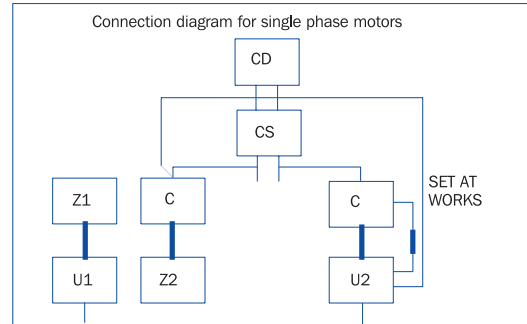
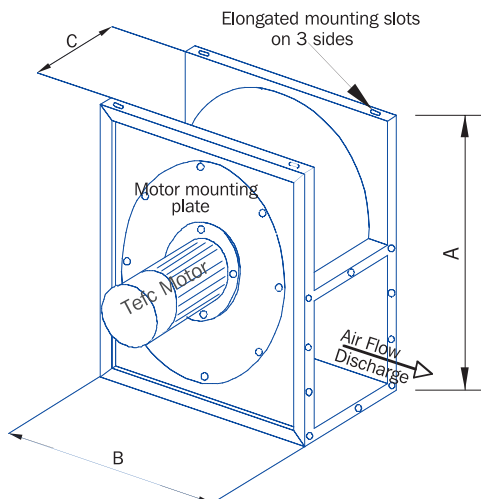

Maintenance

Electrically isolate before commencing work. Remove motor mounting plate and withdraw motor/impeller assembly. Carefully clean rotating parts and check for damage and security of components. The motor is fitted with sealed for life bearings and does not require any further lubrication. Refit motor mounting plate.

One year Warranty

The 1 year warranty starts from the day of delivery and includes parts and labour for the 1st year. This warranty is conditional on a service being carried out after the 1st 3 months and 3 month intervals after that. These intervals may be less if the fan unit operates in adverse conditions.

2 Pole Information

Moduflow Type C Technical Data

Curve	Fan Code	Phase	RPM	kW	flc	s c	125	250	500	1k	2k	4k	8k	dba @ m
1	MODUFLOW 220-32C	3	2800	0.37	1.04	5.20								
1	MODUFLOW 220-12C	1	2800	0.37	2.87	9.76								
2	MODUFLOW 250-32C	3	2800	0.37	1.04	5.20								
2	MODUFLOW 250-12C	1	2800	0.37	2.87	9.76								
3	MODUFLOW 280-32C	3	2800	0.75	1.86	10.23								
3	MODUFLOW 280-12C	1	2800	0.75	5.17	17.58								
4	MODUFLOW 315-32C	3	2800	1.10	2.67	14.69								
4	MODUFLOW 315-12C	1	2880	1.10	6.60	19.14								
5	MODUFLOW 350-32C	3	2800	2.20	4.48	29.12								

The equipment listed above is capable of handling air at temperatures up to 85°C

Performance

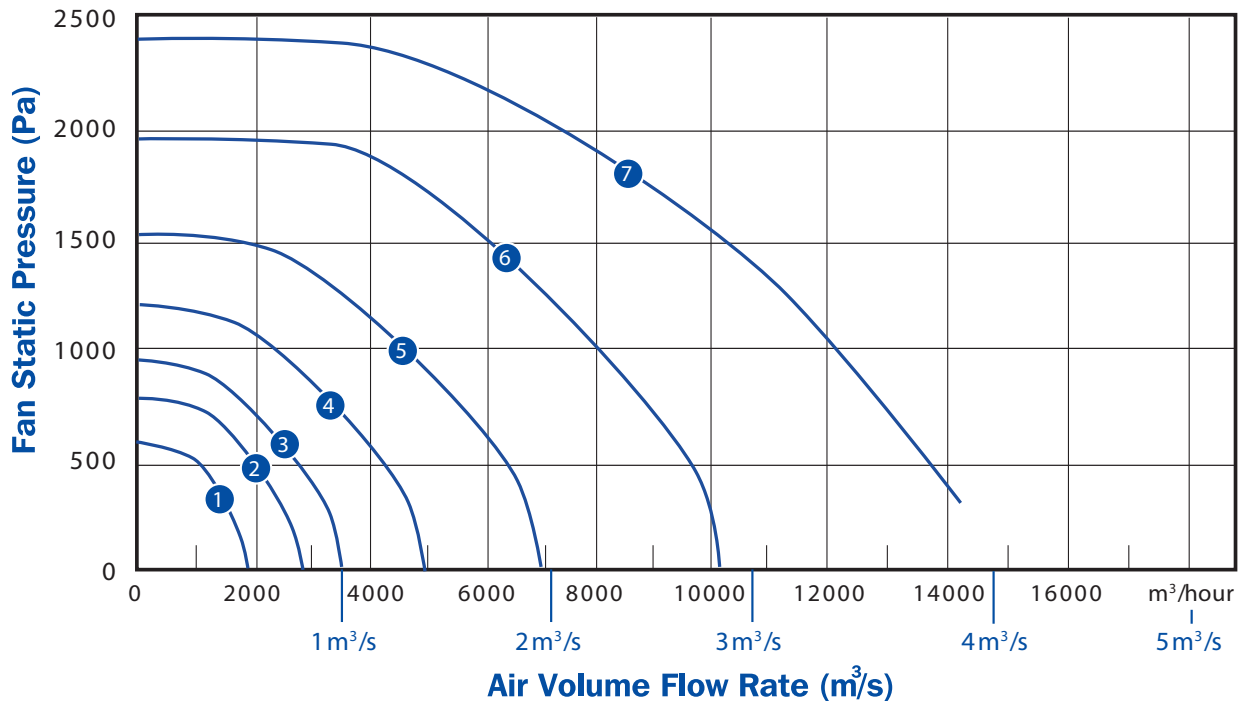

Dimensions & Weights

Unit Size	A	B	C	D	E	F	G	H	J	K	L	M	Weights Kg
220	690	650	340	25	409	267	500	44	330	290	250	315	46
250	790	684	375	29	448	305	534	44	361	3321	281	350	52
280	867	770	413	32	489	330	620	44	398	358	318	400	65
315	950	865	457	37	538	362	715	44	439	399	359	450	82
350	1040	940	498	41	583	394	790	44	430	437	397	500	98
400													
450													

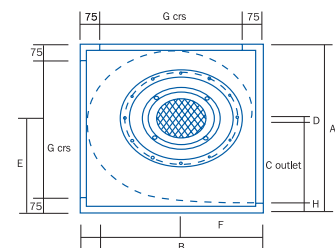
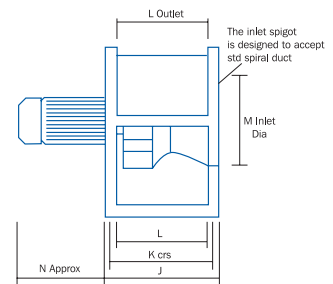

4 Pole Information

Moduflow Type C Technical Data

Curve	Fan Code	Phase	RPM	kW	flc	sc	125	250	500	1k	2k	4k	8k	dba @m
8	MODUFLOW 310-34C	3	1440	0.25	4.5	22								
8	MODUFLOW 310-14C	1	1440	0.25	1.38	8.28								
9	MODUFLOW 350-34C	3	1440	0.37	4.8	31								
9	MODUFLOW 350-14C	1	1440	0.37	1.84	11.04								
10	MODUFLOW 400-34C	3	1440	0.55	10	51								
10	MODUFLOW 400-14C	1	1440	0.55	3.34	21.71								
11	MODUFLOW 450-34C	3	1440	1.1	14.2	74								
11	MODUFLOW 450-14C	1	1440	1.1	4.61	32.27								
12	MODUFLOW 500-34C	3	1440	1.5	7.98	55.86								
12	MODUFLOW 500-14C	1	1440	1.5										
13	MODUFLOW 560-34C	3	1440	3.0										
14	MODUFLOW 630-34C	3	1440	5.5										
15	MODUFLOW 710-34C	3	1440	11.0										
16	MODUFLOW 800-34C	3	1440	15.0										

The equipment listed above is capable of handling air at temperatures up to 85°C

Performance

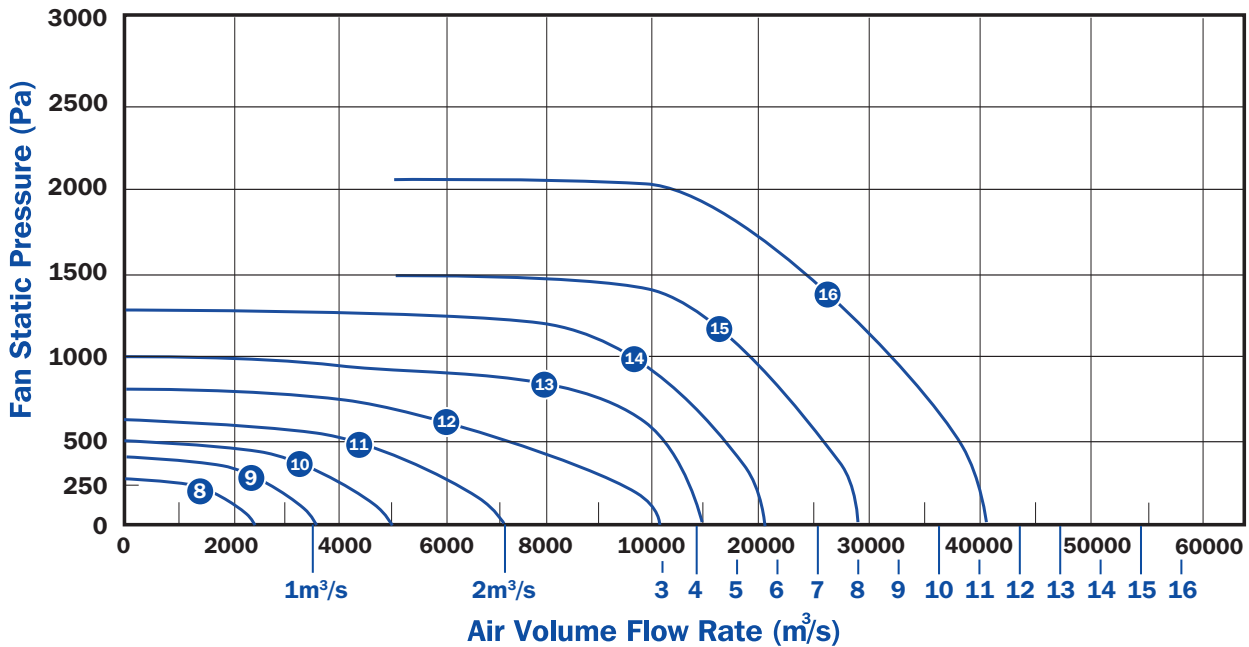

Dimensions & Weights

Unit Size	A	B	C	D	E	F	G	H	J	K	L	M	Weights Kg
310													
350													
400													
450													
500													
560													
630													
710													
800													

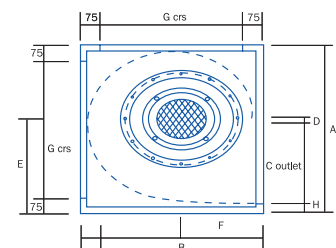
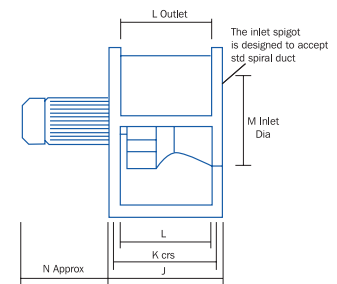

EC DECLARATION OF INCORPORATION FOR PARTY COMPLETED MACHINERY. (MACHINERY DIRECTIVE 2006/42/EC, ANNEX III.B)

Manufacturer: Moduflow Fan Systems Ltd.
Scarth Road
Sowerby Woods Industrial Estate
Barrow-in-Furness
Cumbria LA14 4RF

Type of Machinery: Fan used for moving air or other gases.

Model: BACKWARD CURVED TEMPERATURE FANS

Manufacturer's Ref / Serial No:

I hereby declare that the Essential Health and Safety Requirements of Directive 2006/42/EC that are listed in Annex 1 of this Declaration are applied and fulfilled and that the relevant technical documentation is compiled in accordance with part B of Annex VII of the Directive.

Relevant information on the party completed machinery will be supplied electronically or by post, without prejudice to the intellectual property rights of the manufacturer, in response to a reasoned request by the national authorities.

I furthermore declare that fans manufactured by Moduflow Fan Systems Ltd. are driven by AC induction motors and are inherently compliant with the requirements of the Electromagnetic Compatibility Directive (2004/108/EEC) if supplied with a truly sinusoidal AC supply. Where the fan motor is supplied via a frequency converter or other electronic control, verification of compatibility together with cabling should be sought from the control supplier.

This partly completed machinery must not be put into service until the final machinery or installation into which it is to be incorporated has been declared in conformity with the provisions of Directive 2006/42/EC, where appropriate.

Manufacturer's Representative: R P Whitworth. Position: Director

Signature: Date:

ANNEX I (EC DECLARATION OF INCORPORATION FOR PARTY COMPLETED MACHINERY)

Essential health and safety requirements relating to the design and construction of the Party Completed Machinery.

The following Essential Health and Safety Requirements of Directive 2006/42/EC Annex 1.1, are applied and fulfilled as appropriate:

- 1.1.3 Materials and products
- 1.1.5 Design of machinery to facilitate its handling
- 1.3.1 Risk of loss of stability
- 1.3.2 Risk of break-up during operation
- 1.3.4 Risk due to surfaces, edges or angles
- 1.3.6 Risk related to variations in operating conditions
- 1.5.1 Risk related to electricity supply
- 1.5.4 Errors of fitting
- 1.5.6 Fire
- 1.5.7 Explosion
- 1.5.9 Vibrations
- 1.5.10 Radiation
- 1.5.11 External radiation
- 1.5.13 Emissions of hazardous materials and substances
- 1.6.4 Operator intervention
- 1.7.1 Information and warnings on the machinery
- 1.7.3 Marking of machinery (as appropriate without CE mark)
- 1.7.4 Instructions
 - 1.7.4.1 General principles for the drafting of instructions
 - 1.7.4.2 Contents of the instructions
 - 1.7.4.3 Sales literature

Presumption of conformity with the above listed EHSRs is by application of relevant parts of the following standards:

Applied harmonized standards in particular:
EN ISO 12100-1:2003+A1:2009, EN ISO 12100-2:2003+A1:2009, EN 60204-1:2006+A1:2009, EN ISO 5801:2008 (BS 848-1:2007).

Applied national standards in particular:
BS 848-2.1:2004 (BS ISO 13347-1:2004), BS 848-6:2003 (BS ISO 14695:2003), BS 848-7:2003 (ISO 14694:2003).

INFORMATION FOR SAFE INSTALLATION, OPERATION AND MAINTENANCE OF MODUFLOW LTD VENTILATION EQUIPMENT

To comply with EC Council Directives 2006/42/EC Machinery Directive.
To be read in conjunction with the relevant Product Documentation [see 2.1]

1.0 GENERAL

1.1 The equipment referred to in this Declaration of Incorporation is supplied by Moduflow Ltd to be assembled into a ventilation system which may or may not include additional components.

The entire system must be considered for safety purposes and it is the responsibility of the installer to ensure that all the equipment is installed in compliance with the manufacturers recommendations and with due regard to current legislation and codes of practice.

2.0 INFORMATION SUPPLIED WITH THE EQUIPMENT

2.1 Each item of equipment is supplied with a set of documents which provides the information required for safe installation and maintenance of the equipment. This may be in the form of a Data sheet and/or Installation and Maintenance instruction.

2.2 Each unit has a rating plate attached to its outer casing. The rating plate contains essential data relating to the equipment such as serial number, unit code and electrical data. Any further data that may be required will be found in the documentation. If any item is unclear or more information is required, contact Saverfan.

2.3 Where warning labels or notices are attached to the unit, the instructions given must be adhered to.

3.0 TRANSPORTATION, HANDLING AND STORAGE.

3.1 Care must be taken at all times to prevent damage to the equipment. Note that shock to the unit may result in the balance of the impeller being affected.

3.2 When handling the equipment, care should be taken with corners and edges and that the weight distribution within the unit is considered. Lifting gear such as slings or ropes must be arranged so as not to bear on the casing or impeller/motor.

3.3 Equipment stored on site prior to installation should be protected from the weather and steps taken to prevent the ingress of contaminants.

4.0 OPERATIONAL LIMITS

4.1 It is important that the specified operation limits for the equipment are adhered to e.g. operation air temperatures, air borne contaminants and unit operation.

4.2 Where installation accessories are supplied with the specified equipment e.g. wall mounting brackets or anti-vibration mounts, they are to be used to support the equipment only. Other system components must have separate provision for support.

4.3 Flanges and connection spigots are provided for the purpose of joining to ductwork systems. They must not be used to support the ductwork.

5.0 INSTALLATION REQUIREMENTS

In addition to the particular requirements given for the individual product, the following general requirements should be noted.

5.1 Where access to any part of equipment which moves, or can become electrically live are not prevented by the equipment panels or by fixed installation detail [e.g ducting], then guarding to the appropriate standard must be fitted.

5.2 The electrical installation of the equipment must comply with the requirements of the relevant local electrical standards.

6.0 COMMISSIONING REQUIREMENTS

6.1 General pre-commissioning checks relevant to safe operation consist of the following:

Ensure that no foreign bodies are present within the fan or casing.

Check electrical safety, eg. Insulation and earthing.

Check guarding of system.

Check operation of Isolators/controls.

Check fastenings for security.

6.2 Other commissioning requirements are given in the relevant product documentation.

7.0 OPERATIONAL REQUIREMENTS

7.1 Equipment access panels must be in place at all times during operation of the unit and must be secured with the original fastenings.

7.2 If failure of equipment occurs or is suspected then it should be taken out of service until a competent person can effect repair or examination. [Note that certain ranges of equipment are designed to detect and compensate for fan failure].

8.0 MAINTENANCE REQUIREMENTS

8.1 Specific maintenance requirements are given in the relevant documentation.

8.2 It is important that the correct tools are used for the various tasks required.

8.3 If the access panels are to be removed for any reason the electrical supply to the unit must be isolated.

8.4 A minimum period of 2 minutes should be allowed after electrical disconnection before access panels are removed. This will allow the impeller to come to rest.

NB: Care should still be taken however since airflow generated at some other point in the system can cause the impeller to 'windmill'.

8.5 Care should be taken when removing and storing access panels in windy conditions.