



ERR Centrifugal duct fans

- For commercial use: Durable, powerful and robust.
- Ventilation or air extraction, depending on the installation direction.
- Reduced dimensions.
- Can be fitted in any position.
- Up to 2,350 m³/h

Application examples

- Machine extraction unit
- Workplace air extraction system
- Production site
- Storage facility
- Laboratory

- Supply of small to medium air volumes at high resistances.
- Installation in DN 100 - DN 355 ventilation ducts.
- Centrifugal impeller with backwards curved blades.
- Inlet and outlet side connection couplings for direct installation in ventilation ducts.

Motor

- External rotor - capacitor motor.
- Operating capacitor in the terminal box is ready to be connected.
- Speed controllable.
- Thermal overload protection as standard feature.
- Robust motor with ball bearings, maintenance-free.
- IP X4 degree of protection when installed in ventilation ducts with at least 1 m of duct on the inlet and outlet sides.

Electrical connection

- Externally fitted terminal box with cable guide bushes.

ERR Product Range

Type	Nominal Size	Rated Voltage	Air flow Volume	Degree of protection (IP)
ERR 10/1	100mm	230V~	220m ³ /h	X4
ERR 10/1S	100mm	230V~	250m ³ /h	X4
ERR 12/1	125mm	230V~	300m ³ /h	X4
ERR 15/1	160mm	230V~	400m ³ /h	X4
ERR 15/1S	160mm	230V~	800m ³ /h	X4
ERR 20/1	200mm	230V~	900m ³ /h	X4
ERR 20/1S	200mm	230V~	1000m ³ /h	X4
ERR 25/1	250mm	230V~	1150m ³ /h	X4
ERR 31/1	315mm	230V~	1350m ³ /h	X4
ERR 31/1S	315mm	230V~	1700m ³ /h	X4
ERR 35/1	350mm	230V~	2200m ³ /h	X4
ERR 35/1S	350mm	230V~	2350m ³ /h	X4

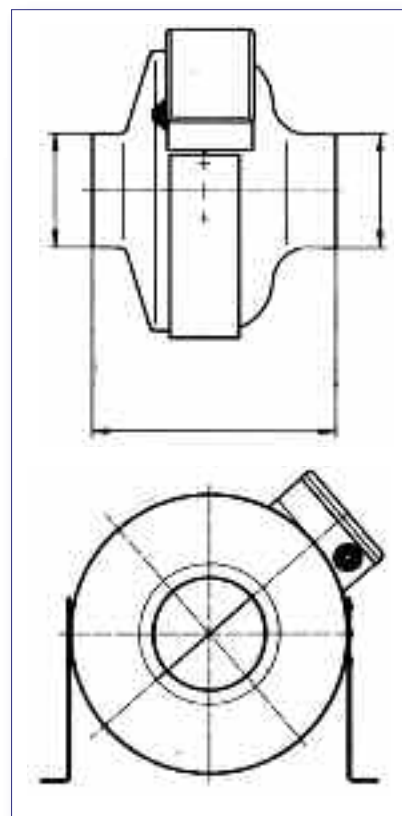

Performance Curve ERR 10/1

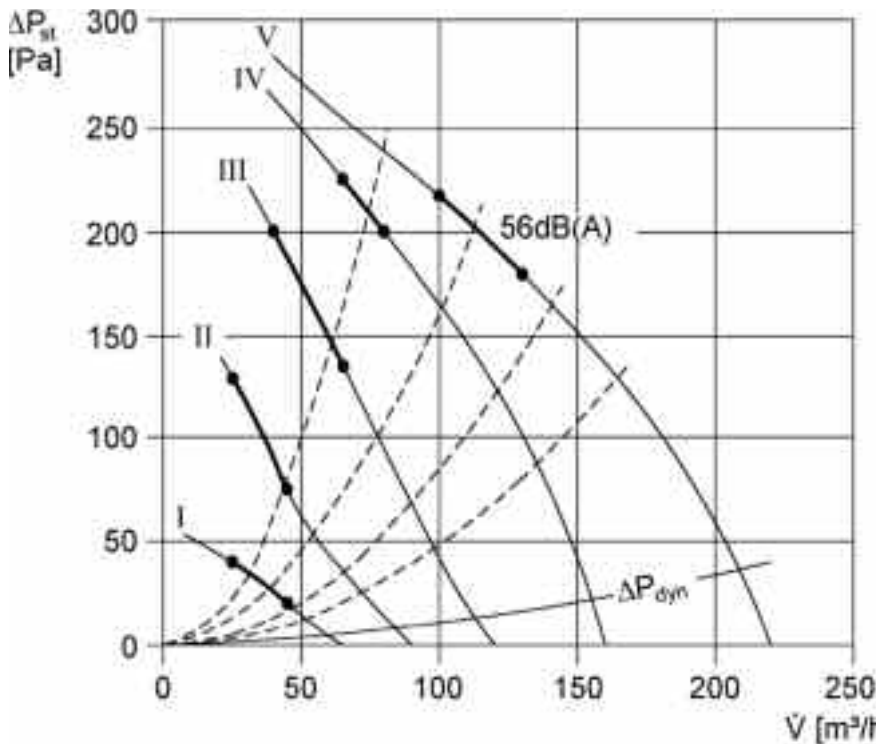

Technical data

Air flow volume	220m ³ /h
Rotating speed	1,900 1/min
Speed controllable	Yes
Type of voltage	Alternating current
Rated voltage	230 V
Power frequency	50 Hz
Nominal output	45W
I_N	0.2A
I_{MAX}	0.28A

Degree of protection (IP)	X4
Insulation class	F
Installation position	vertical/horizontal
Housing material	sheet steel, powder coated
Weight	3.8kg
Nominal size	100mm
Airstream temperature (nominal)	60°C
Airstream temperature at I_{MAX}	60°C
EAN	4012799802709

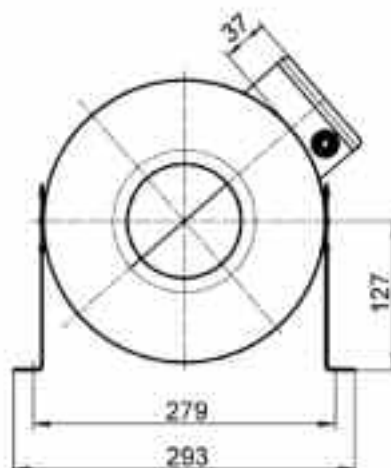
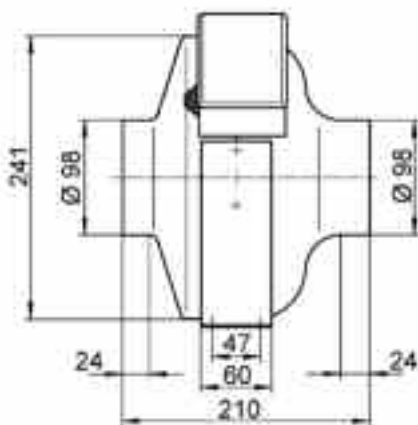

Application examples

- Machine extraction unit
- Workplace air extraction system
- Production site
- Storage facility
- Laboratory

Accessories for ERR 10/1

Shutter	AP 100
Shutter	AP 100 B
Automatic backflow preventer	AVM 10
External grille	SG 100
External grille	SG 100 B
Internal grilles	LGA, LGZ
Protective grille	SGR 10
Disk valves, synthetic material	TK
Disk valves, metal	TM
Disk valves, fire protection	TB, WBV
Tubular sound absorber	RSR 10
Tubular sound absorber	RSR 10/50
Heat exchanger	WT 300
Electrical air heater	ERH 10-04
Water air heater	WRH 10-1
Fixing cuff	ELR 10
Mounting foot	FUR 10/12/16
Air filter	TFE 10-4
Air filter	TFE 10-5
Air filter	TFE 10-7
Speed controller	ST 1
Speed controller	STU 1
Speed controller, distribution board	STS 2,5
5-step transformer	TRE 0,4
5-step transformer, control cabinet	TRE 1,6 S
5-step switch for 5-step transformer	ESS 20
Step switch, reversing switch	FS 4

Performance Curve ERR 10/1S

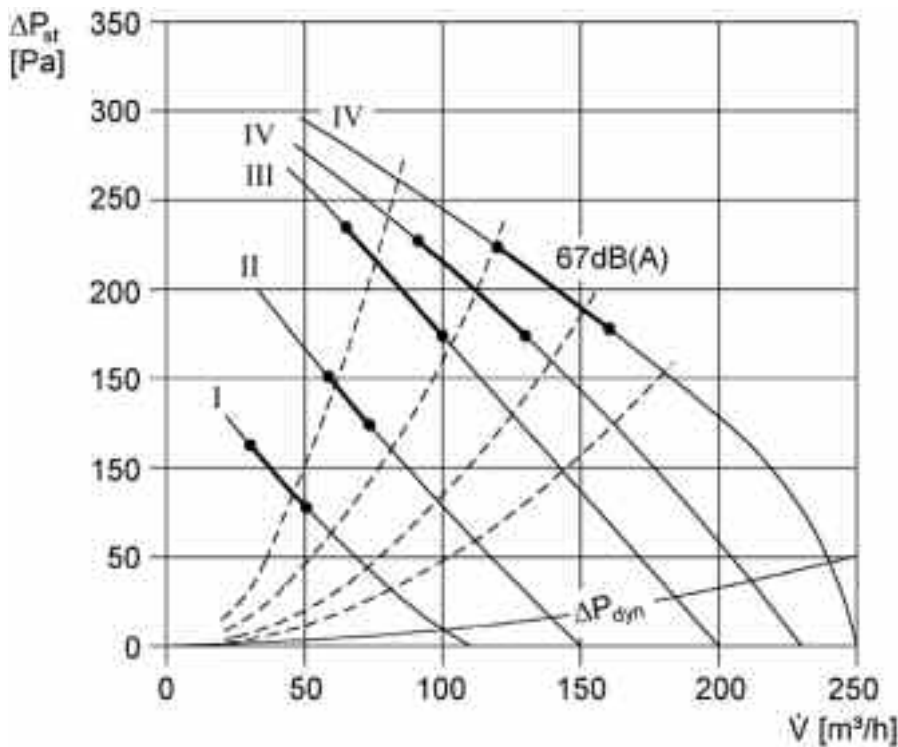

Technical data

Air flow volume	250m ³ /h	Degree of protection (IP)	X4
Rotating speed	2520 1/min	Insulation class	F
Speed controllable	Yes	Installation position	vertical/horizontal
Type of voltage	Alternating current	Housing material	sheet steel, powder coated
Rated voltage	230 V	Weight	3.84kg
Power frequency	50 Hz	Nominal size	100mm
Nominal output	50W	Airstream temperature (nominal)	60°C
I_N	0.22A	Airstream temperature at I_{MAX}	60°C
I_{MAX}	0.25A	EAN	4012799802716

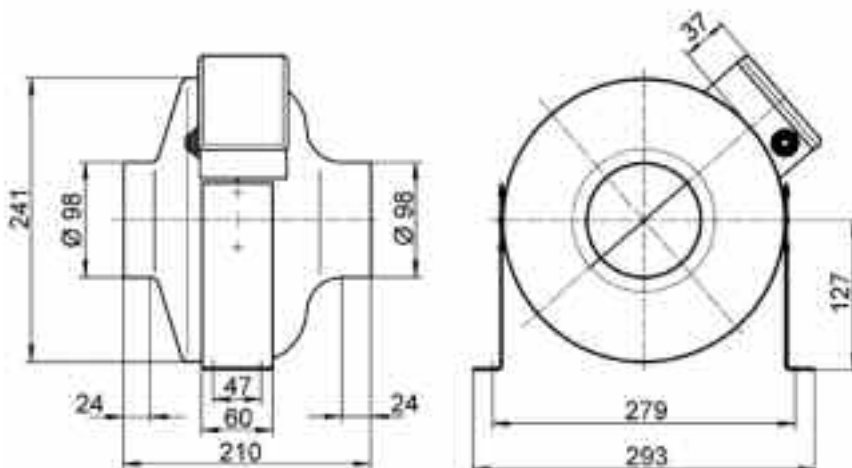

Application examples

- Machine extraction unit
- Workplace air extraction system
- Production site
- Storage facility
- Laboratory

Accessories for ERR 10/1S

Shutter	AP 100
Shutter	AP 100 B
Automatic backflow preventer	AVM 10
External grille	SG 100
External grille	SG 100 B
Internal grilles	LGA, LGZ
Protective grille	SGR 10
Disk valves, synthetic material	TK
Disk valves, metal	TM
Disk valves, fire protection	TB, WBV
Tubular sound absorber	RSR 10
Tubular sound absorber	RSR 10/50
Heat exchanger	WT 300
Electrical air heater	ERH 10-04
Water air heater	WRH 10-1
Fixing cuff	ELR 10
Mounting foot	FUR 10/12/16
Air filter	TFE 10-4
Air filter	TFE 10-5
Air filter	TFE 10-7
Speed controller	ST 1
Speed controller	STU 1
Speed controller, distribution board	STS 2,5
5-step transformer	TRE 0,4
5-step transformer, control cabinet	TRE 1,6 S
5-step switch for 5-step transformer	ESS 20
Step switch, reversing switch	FS 4

Performance Curve ERR 12/1

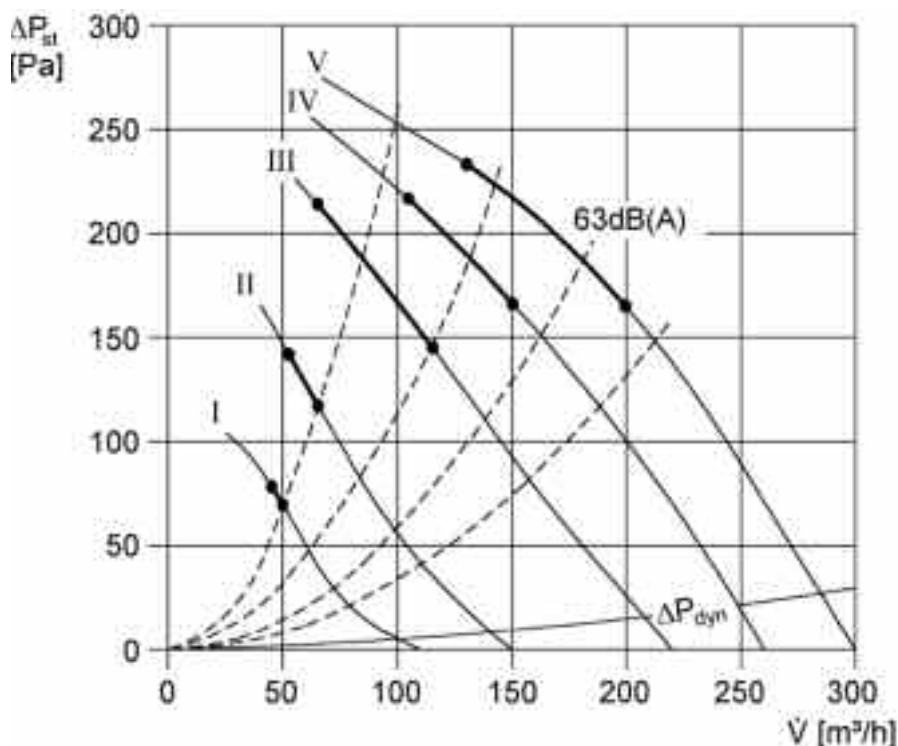

Technical data

Air flow volume	300m³/h
Rotating speed	2400 1/min
Speed controllable	Yes
Type of voltage	Alternating current
Rated voltage	230 V
Power frequency	50 Hz
Nominal output	50W
I_N	0.22A
I_{MAX}	0.26A

Degree of protection (IP)	X4
Insulation class	F
Installation position	vertical/horizontal
Housing material	sheet steel, powder coated
Weight	3.3kg
Nominal size	125mm
Airstream temperature (nominal)	60°C
Airstream temperature at I_{MAX}	60°C
EAN	4012799802723

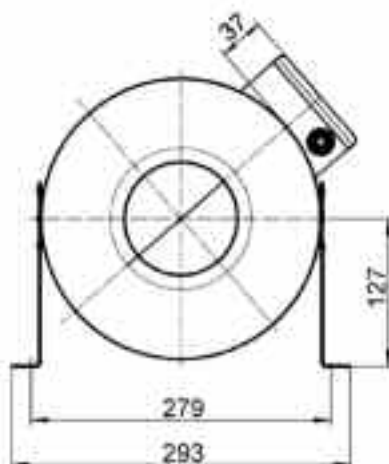
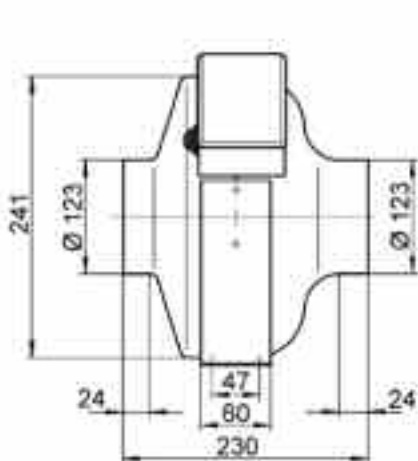

Application examples

- Machine extraction unit
- Workplace air extraction system
- Production site
- Storage facility
- Laboratory

Accessories for ERR 12/1

Shutter	AP 120
Automatic backflow preventer	AVM 12
External grille	SG 120
Internal grilles	LGA, LGZ
Protective grille	SGR 12
Disk valves, synthetic material	TK
Disk valves, metal	TM
Disk valves, fire protection	TB, WBV
Tubular sound absorber	RSR 12
Tubular sound absorber	RSR 12/50
Heat exchanger	WT 300
Electrical air heater	ERH 12-1
Water air heater	WRH 12-1
Fixing cuff	ELR 12
Mounting foot	FUR 10/12/16
Air filter	TFE 12-4
Air filter	TFE 12-5
Air filter	TFE 12-7
Speed controller	ST 1
Speed controller	STU 1
Speed controller, distribution board	STS 2,5
5-step transformer	TRE 0,4
5-step transformer, control cabinet	TRE 1,6 S
5-step switch for 5-step transformer	ESS 20
Step switch, reversing switch	FS 4

Performance Curve ERR 15/1

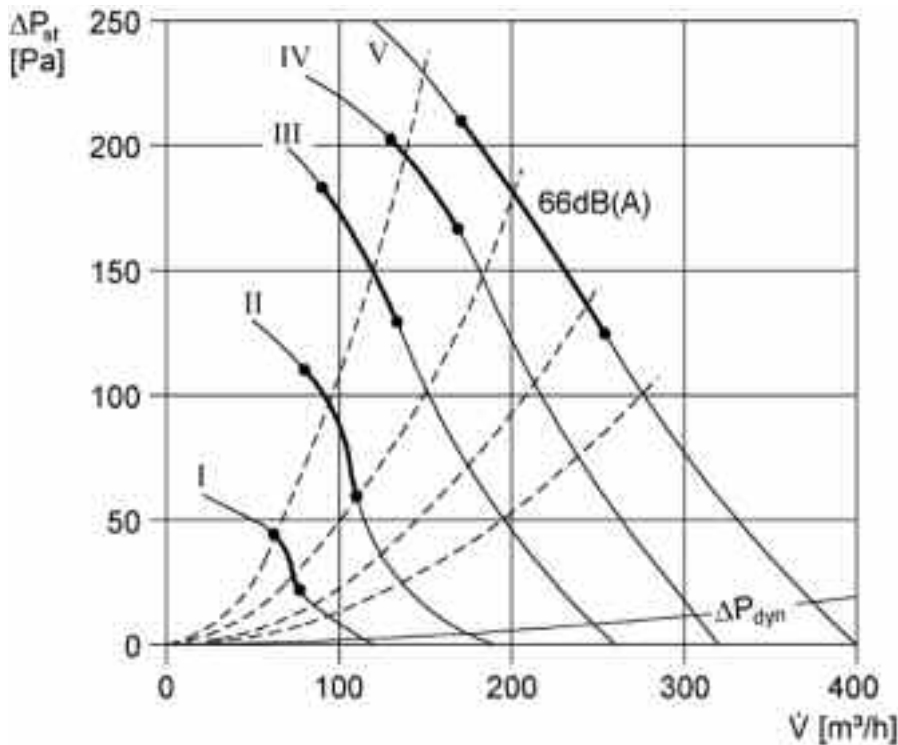

Technical data

Air flow volume	400m ³ /h	Degree of protection (IP)	X4
Rotating speed	2330 1/min	Insulation class	F
Speed controllable	Yes	Installation position	vertical/horizontal
Type of voltage	Alternating current	Housing material	sheet steel, powder coated
Rated voltage	230 V	Weight	3.8kg
Power frequency	50 Hz	Nominal size	160mm
Nominal output	60W	Airstream temperature (nominal)	60°C
I_N	0.26A	Airstream temperature at I_{MAX}	60°C
I_{MAX}	0.3A	EAN	4012799802730

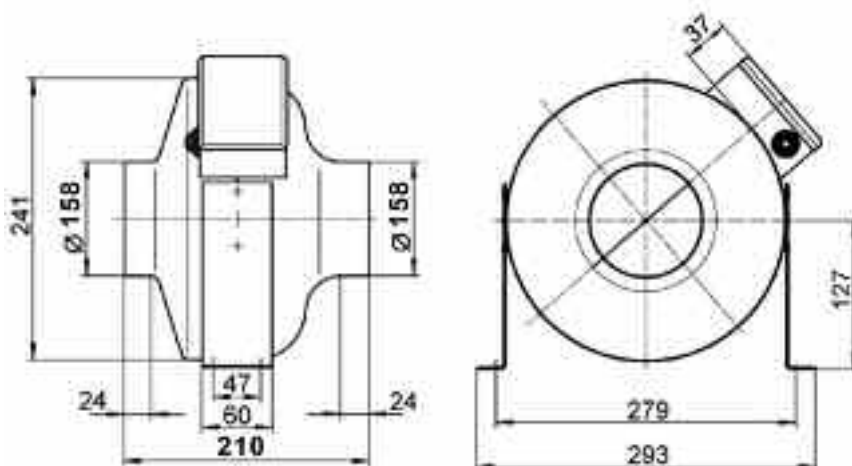

Application examples

- Machine extraction unit
- Workplace air extraction system
- Production site
- Storage facility
- Laboratory

Accessories for ERR 15/1

Automatic backflow preventer	AVM 16
Internal grilles	LGA, LGZ
Protective grille	SGR 16
Disk valves, synthetic material	TK
Disk valves, metal	TM
Disk valves, fire protection	TB, WBV
Tubular sound absorber	RSR 16
Tubular sound absorber	RSR 16/50
Heat exchanger	WT 300
Electrical air heater	ERH 16-2
Electrical air heater	DRH 16-5
Electrical air heater with controller	DRH 16-5 R
Water air heater	WRH 16-2
Fixing cuff	ELR 16
Mounting foot	FUR 10/12/16
Air filter	TFE 16-4
Air filter	TFE 16-5
Air filter	TFE 16-7
Speed controller	ST 1
Speed controller	STU 1
Speed controller, distribution board	STS 2,5
5-step transformer	TRE 0,4
5-step transformer, control cabinet	TRE 1,6 S
5-step switch for 5-step transformer	ESS 20
Step switch, reversing switch	FS 4

Performance Curve ERR 15/1S

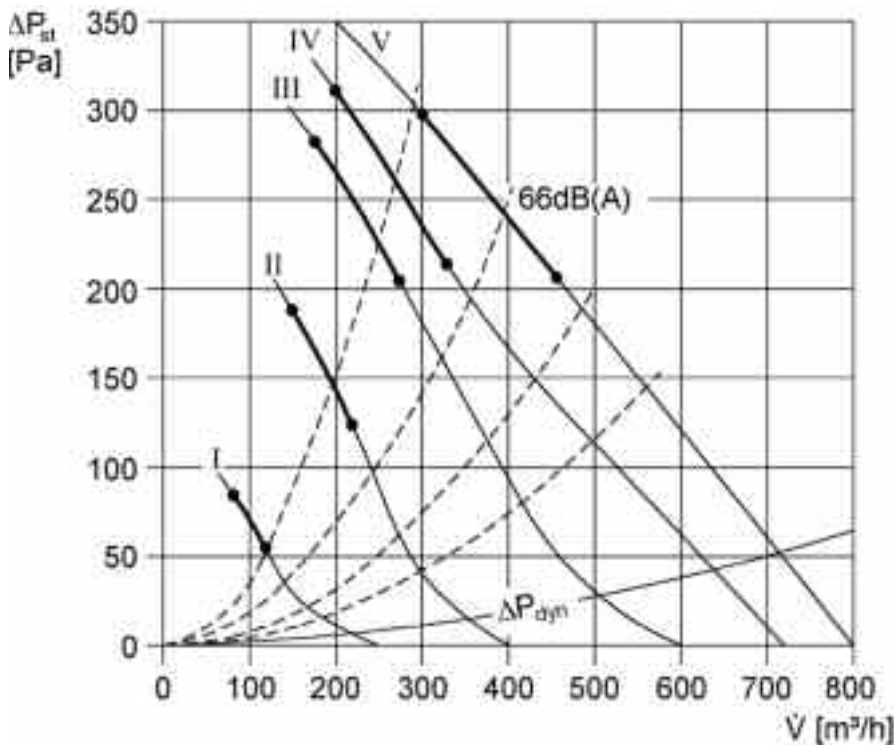

Technical data

Air flow volume	800m ³ /h
Rotating speed	2550 1/min
Speed controllable	Yes
Type of voltage	Alternating current
Rated voltage	230 V
Power frequency	50 Hz
Nominal output	120W
I_N	0.55A
I_{MAX}	0.55A

Degree of protection (IP)	X4
Insulation class	F
Installation position	vertical/horizontal
Housing material	sheet steel, powder coated
Weight	5.5kg
Nominal size	160mm
Airstream temperature (nominal)	40°C
Airstream temperature at I_{MAX}	40°C
EAN	4012799802747

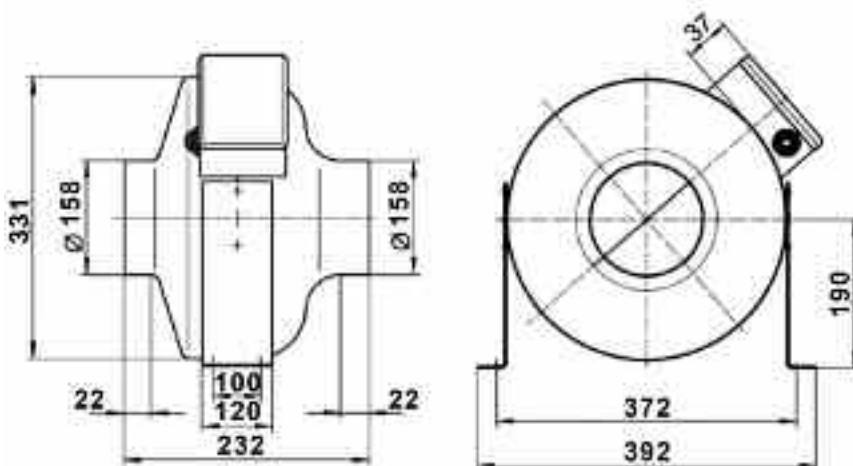

Application examples

- Machine extraction unit
- Workplace air extraction system
- Production site
- Storage facility
- Laboratory

Accessories for ERR 15/1S

Automatic backflow preventer	AVM 16
Internal grilles	LGA, LGZ
Protective grille	SGR 16
Disk valves, synthetic material	TK
Disk valves, metal	TM
Disk valves, fire protection	TB, WBV
Tubular sound absorber	RSR 16
Tubular sound absorber	RSR 16/50
Heat exchanger	WT 300
Electrical air heater	ERH 16-2
Electrical air heater	DRH 16-5
Electrical air heater with controller	DRH 16-5 R
Water air heater	WRH 16-2
Fixing cuff	ELR 16
Mounting foot	FUR 16S/20/25
Air filter	TFE 16-4
Air filter	TFE 16-5
Air filter	TFE 16-7
Speed controller	ST 1
Speed controller	STU 1
Speed controller, distribution board	STS 2,5
5-step transformer	TRE 0,6
5-step transformer, control cabinet	TRE 1,6 S
5-step switch for 5-step transformer	ESS 20

Performance Curve ERR 20/1

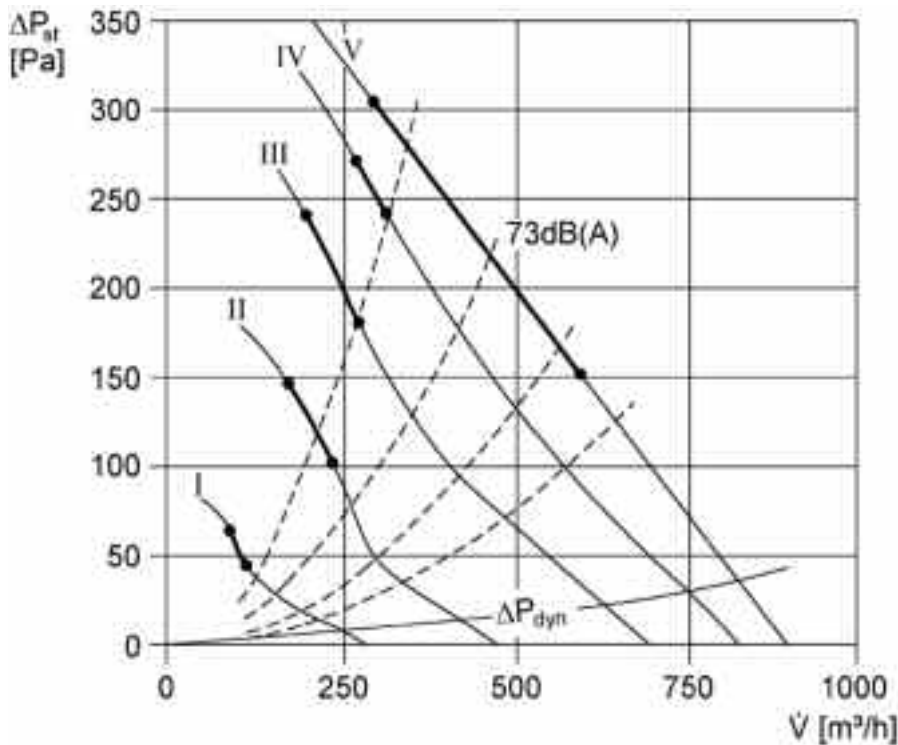

Technical data

Air flow volume	900m ³ /h	Degree of protection (IP)	X4
Rotating speed	2660 1/min	Insulation class	F
Speed controllable	Yes	Installation position	vertical/horizontal
Type of voltage	Alternating current	Housing material	sheet steel, powder coated
Rated voltage	230 V	Weight	5.14kg
Power frequency	50 Hz	Nominal size	200mm
Nominal output	115W	Airstream temperature (nominal)	55°C
I_N	0.55A	Airstream temperature at I_{MAX}	55°C
I_{MAX}	0.55A	EAN	4012799802754

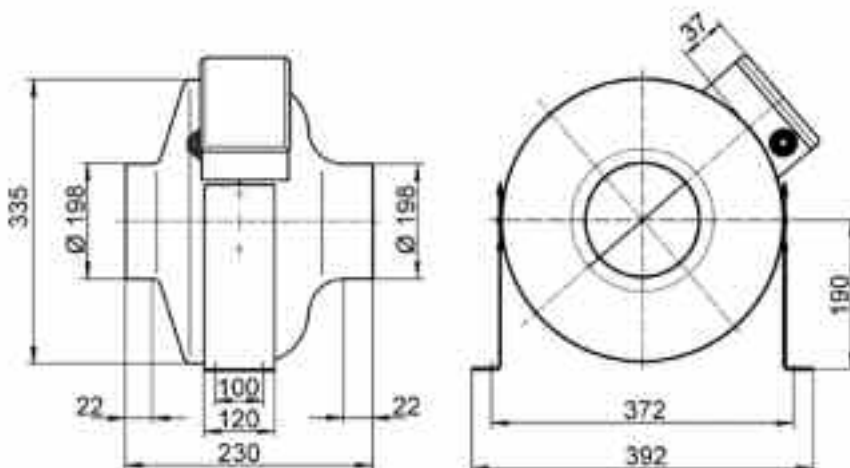

Application examples

- Machine extraction unit
- Workplace air extraction system
- Production site
- Storage facility
- Laboratory

Accessories for ERR 20/1

Shutter	AS 20
Servomotor	MS 2
Automatic backflow preventer	AVM 20
External grille	MLA 20
External grille	MLZ 20
Internal grilles	LGA, LGZ
Protective grille	SGR 20
Disk valves, synthetic material	TK
Disk valves, metal	TM
Disk valves, fire protection	TB, WBV
Tubular sound absorber	RSR 20
Tubular sound absorber	RSR 20/50
Heat exchanger	WT 750
Electrical air heater	ERH 20-2
Electrical air heater	DRH 20-5
Electrical air heater with controller	DRH 20-6 R
Water air heater	WRH 20-2
Fixing cuff	ELR 20
Mounting foot	FUR 16S/20/25
Air filter	TFE 20-4
Air filter	TFE 20-5
Air filter	TFE 20-7
Speed controller	ST 1
Speed controller	STU 1
Speed controller, distribution board	STS 2,5
5-step transformer	TRE 0,6
5-step transformer, control cabinet	TRE 1,6 S
5-step switch for 5-step transformer	ESS 20

Performance Curve ERR 20/1S

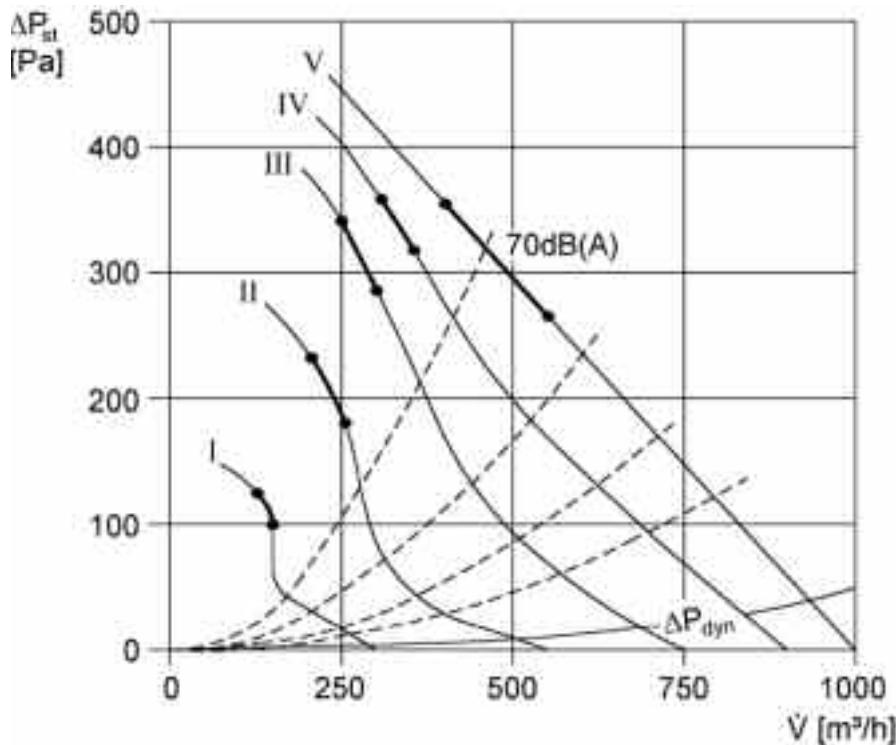

Technical data

Air flow volume	1000m³/h	Degree of protection (IP)	X4
Rotating speed	2590 1/min	Insulation class	F
Speed controllable	Yes	Installation position	vertical/horizontal
Type of voltage	Alternating current	Housing material	sheet steel, powder coated
Rated voltage	230 V	Weight	6kg
Power frequency	50 Hz	Nominal size	200mm
Nominal output	150W	Airstream temperature (nominal)	40°C
I_N	0.7A	Airstream temperature at I_{MAX}	40°C
I_{MAX}	0.7A	EAN	4012799802761

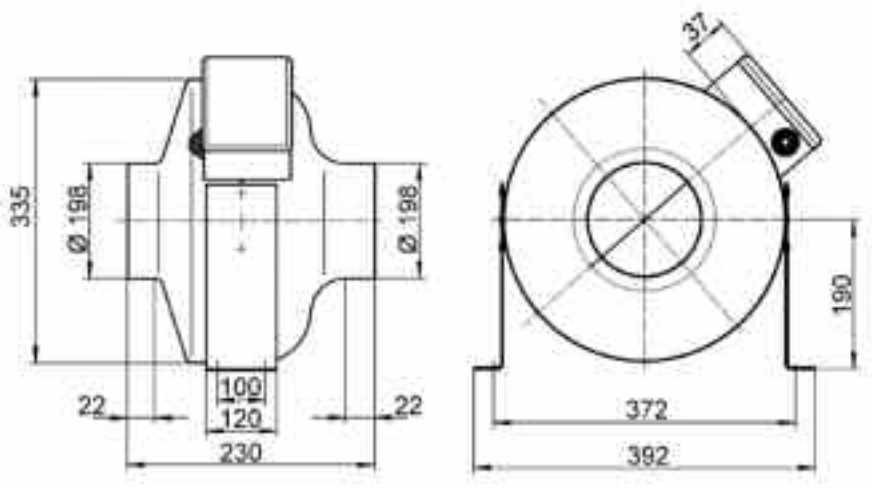

Application examples

- Machine extraction unit
- Workplace air extraction system
- Production site
- Storage facility
- Laboratory

Accessories for ERR 20/1S

Shutter	AS 20
Servomotor	MS 2
Automatic backflow preventer	AVM 20
External grille	MLA 20
External grille	MLZ 20
Internal grilles	LGA, LGZ
Protective grille	SGR 20
Disk valves, synthetic material	TK
Disk valves, metal	TM
Disk valves, fire protection	TB, WBV
Tubular sound absorber	RSR 20
Tubular sound absorber	RSR 20/50
Heat exchanger	WT 750
Electrical air heater	ERH 20-2
Electrical air heater	DRH 20-5
Electrical air heater with controller	DRH 20-6 R
Water air heater	WRH 20-2
Fixing cuff	ELR 20
Mounting foot	FUR 16S/20/25
Air filter	TFE 20-4
Air filter	TFE 20-5
Air filter	TFE 20-7
Speed controller	ST 1
Speed controller	STU 1
Speed controller, distribution board	STS 2,5
5-step transformer	TRE 1,6
5-step transformer, control cabinet	TRE 1,6 S
5-step switch for 5-step transformer	ESS 20

Performance Curve ERR 25/1

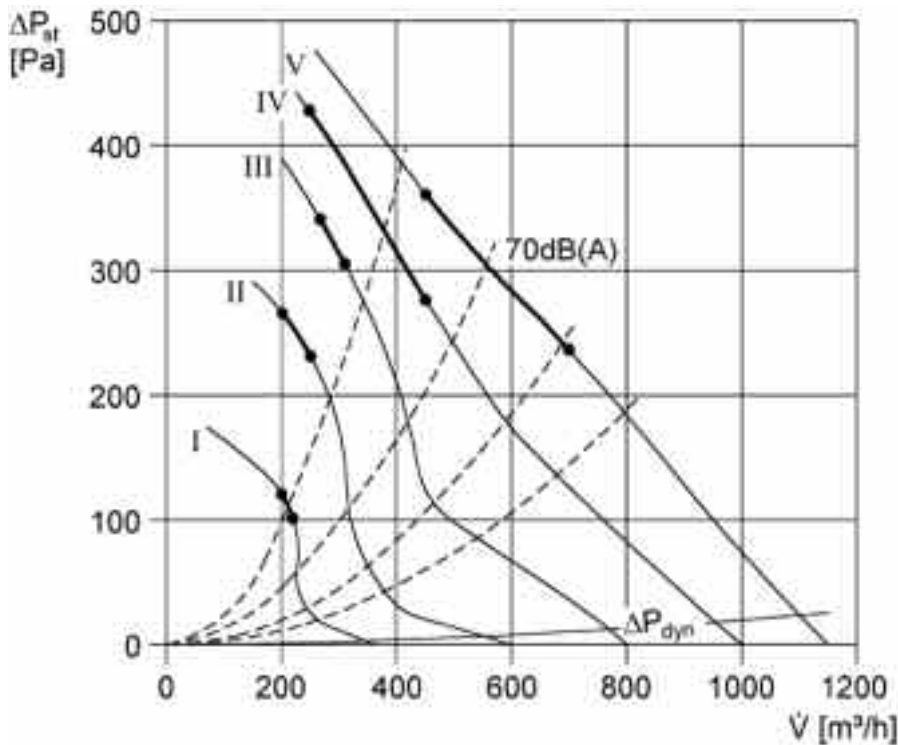

Technical data

Air flow volume	1150m³/h	Degree of protection (IP)	X4
Rotating speed	2560 1/min	Insulation class	F
Speed controllable	Yes	Installation position	vertical/horizontal
Type of voltage	Alternating current	Housing material	sheet steel, powder coated
Rated voltage	230 V	Weight	6.3kg
Power frequency	50 Hz	Nominal size	250mm
Nominal output	180W	Airstream temperature (nominal)	45°C
I_N	0.8A	Airstream temperature at I_{MAX}	45°C
I_{MAX}	0.85A	EAN	4012799802778

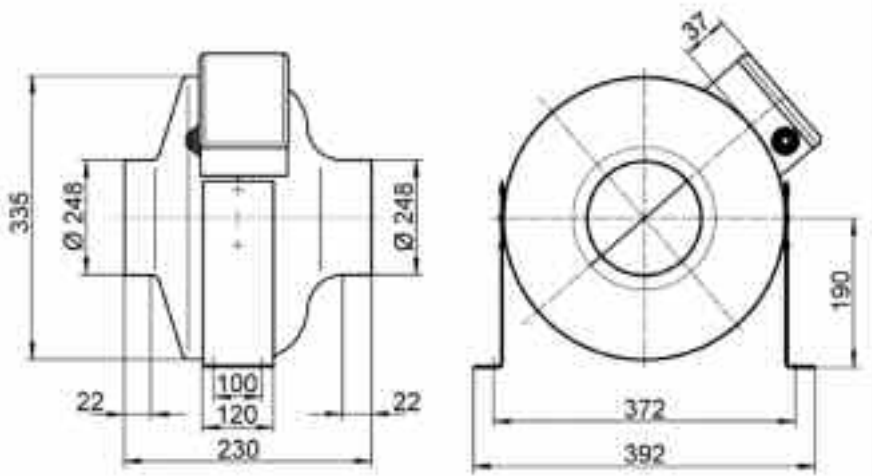

Application examples

- Machine extraction unit
- Workplace air extraction system
- Production site
- Storage facility
- Laboratory

Accessories for ERR 25/1

Shutter	AS 25
Servomotor	MS 2
Automatic backflow preventer	AVM 25
External grille	MLA 25
External grille	MLZ 25
Internal grilles	LGA, LGZ
Protective grille	SGR 25
Disk valves, synthetic material	TK
Disk valves, metal	TM
Disk valves, fire protection	TB, WBV
Tubular sound absorber	RSR 25
Tubular sound absorber	RSR 25/50
Heat exchanger	WT 750
Electrical air heater	ERH 25-2
Electrical air heater	DRH 25-6
Electrical air heater with controller	DRH 25-9 R
Water air heater	WRH 25-4
Fixing cuff	ELR 25
Mounting foot	FUR 16S/20/25
Air filter	TFE 25-4
Air filter	TFE 25-5
Air filter	TFE 25-7
Speed controller	ST 1
Speed controller	STU 1
Speed controller, distribution board	STS 2,5
5-step transformer	TRE 1,6
5-step transformer, control cabinet	TRE 1,6 S
5-step switch for 5-step transformer	ESS 20

Performance Curve ERR 31/1S

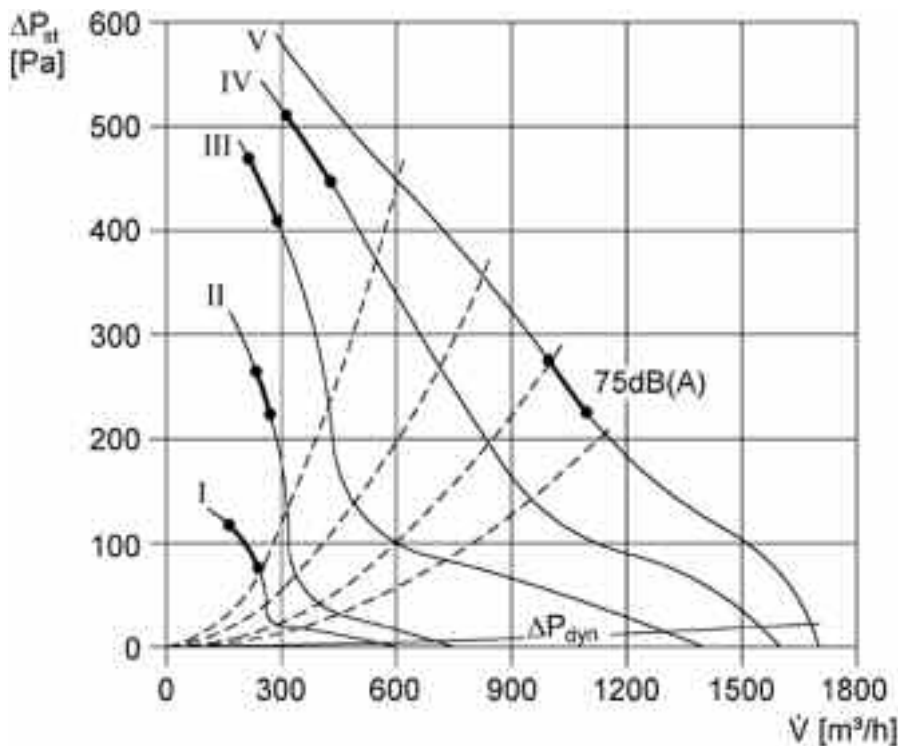

Technical data

Air flow volume	1700m ³ /h
Rotating speed	2630 1/min
Speed controllable	Yes
Type of voltage	Alternating current
Rated voltage	230 V
Power frequency	50 Hz
Nominal output	280W
I_N	1.2A
I_{MAX}	1.4A

Degree of protection (IP)	X4
Insulation class	F
Installation position	vertical/horizontal
Housing material	sheet steel, powder coated
Weight	7.72kg
Nominal size	315mm
Airstream temperature (nominal)	40°C
Airstream temperature at I_{MAX}	40°C
EAN	4012799802792

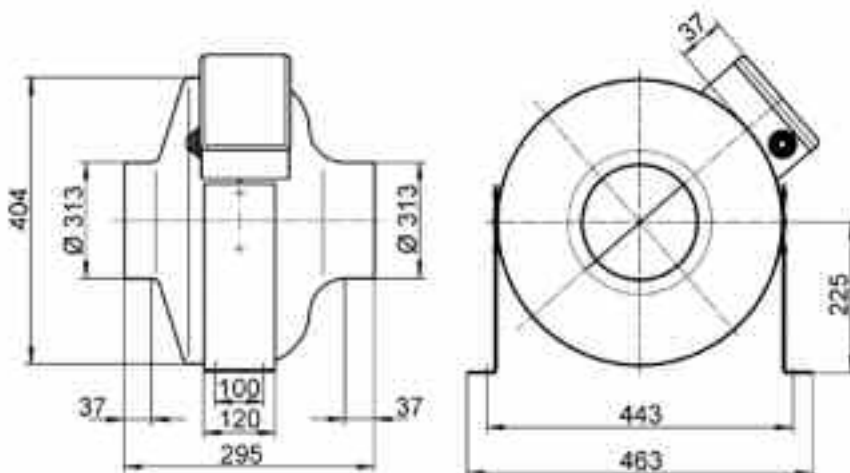

Application examples

- Machine extraction unit
- Workplace air extraction system
- Production site
- Storage facility
- Laboratory

Accessories for ERR 31/1S

Shutter	AS 35
Servomotor	MS 2
Automatic backflow preventer	AVM 31
External grille	MLA 30
External grille	MLZ 30
Internal grilles	LGA, LGZ
Protective grille	SGR 31
Disk valves, synthetic material	TK
Disk valves, metal	TM
Disk valves, fire protection	TB, WBV
Tubular sound absorber	RSR 31
Tubular sound absorber	RSR 31/50
Heat exchanger	WT 1500
Electrical air heater	DRH 31-6
Electrical air heater with controller	DRH 31-12 R
Water air heater	WRH 25-4
Water air heater	WRH 31-6
Fixing cuff	ELR 31
Mounting foot	FUR 31/1
Air filter	TFE 31-4
Air filter	TFE 31-5
Air filter	TFE 31-7
Speed controller	ST 2,5
Speed controller	STU 2,5
Speed controller, distribution board	STS 2,5
5-step transformer	TRE 1,6
5-step transformer, control cabinet	TRE 1,6 S
5-step switch for 5-step transformer	ESS 20

Performance Curve ERR 31/1S

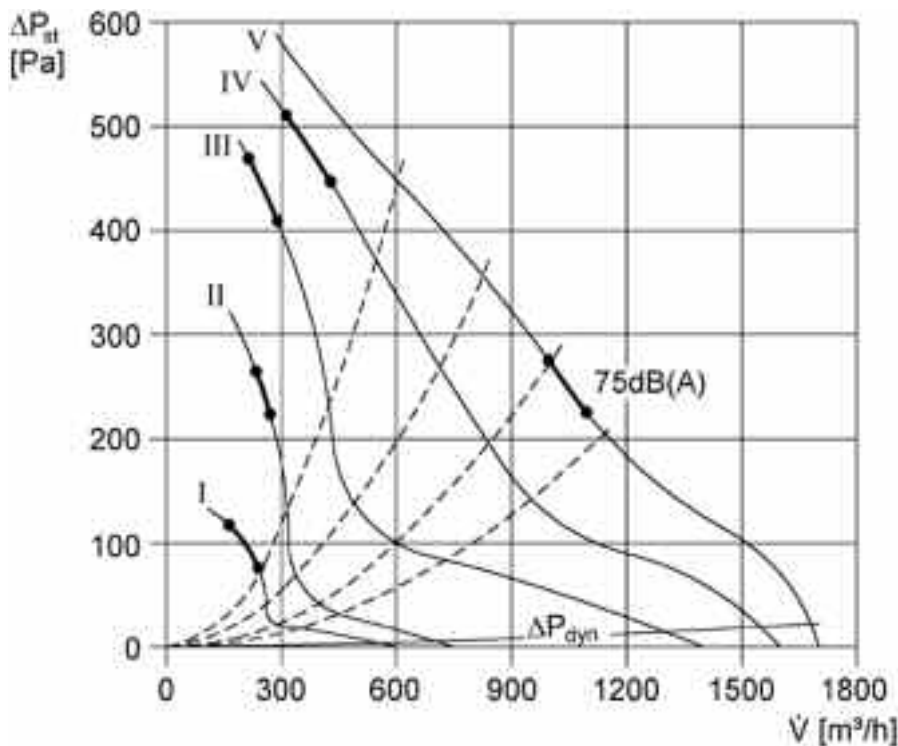

Technical data

Air flow volume	1700m ³ /h	Degree of protection (IP)	X4
Rotating speed	2630 1/min	Insulation class	F
Speed controllable	Yes	Installation position	vertical/horizontal
Type of voltage	Alternating current	Housing material	sheet steel, powder coated
Rated voltage	230 V	Weight	7.72kg
Power frequency	50 Hz	Nominal size	315mm
Nominal output	280W	Airstream temperature (nominal)	40°C
I_N	1.2A	Airstream temperature at I_{MAX}	40°C
I_{MAX}	1.4A	EAN	4012799802792

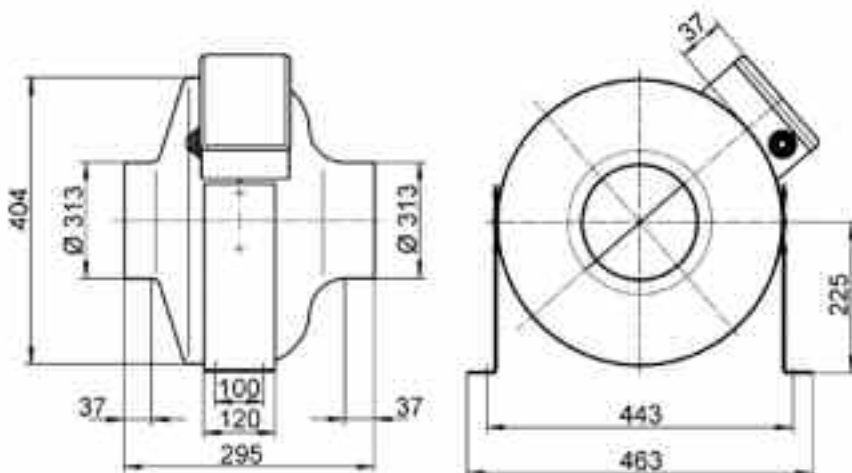

Application examples

- Machine extraction unit
- Workplace air extraction system
- Production site
- Storage facility
- Laboratory

Accessories for ERR 31/1S

Shutter	AS 35
Servomotor	MS 2
Automatic backflow preventer	AVM 31
External grille	MLA 30
External grille	MLZ 30
Internal grilles	LGA, LGZ
Protective grille	SGR 31
Disk valves, synthetic material	TK
Disk valves, metal	TM
Disk valves, fire protection	TB, WBV
Tubular sound absorber	RSR 31
Tubular sound absorber	RSR 31/50
Heat exchanger	WT 1500
Electrical air heater	DRH 31-6
Electrical air heater with controller	DRH 31-12 R
Water air heater	WRH 25-4
Water air heater	WRH 31-6
Fixing cuff	ELR 31
Mounting foot	FUR 31/1
Air filter	TFE 31-4
Air filter	TFE 31-5
Air filter	TFE 31-7
Speed controller	ST 2,5
Speed controller	STU 2,5
Speed controller, distribution board	STS 2,5
5-step transformer	TRE 1,6
5-step transformer, control cabinet	TRE 1,6 S
5-step switch for 5-step transformer	ESS 20

Performance Curve ERR 35/1

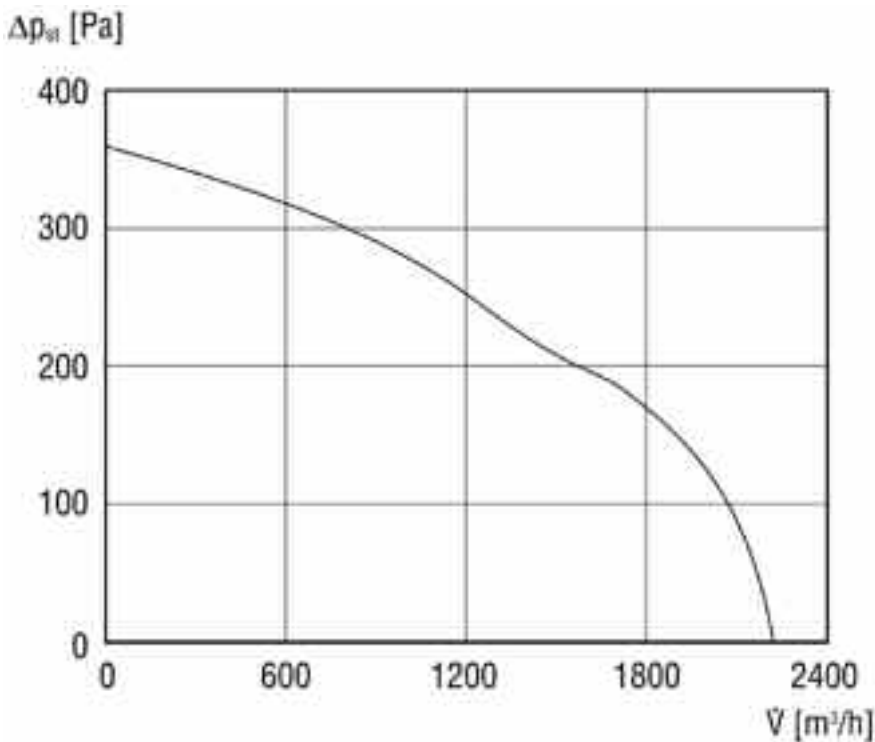

Technical data

Air flow volume	2200m³/h
Rotating speed	1330 1/min
Speed controllable	Yes
Type of voltage	Alternating current
Rated voltage	230 V
Power frequency	50 Hz
Nominal output	248W
I_N	
I_{MAX}	1.12A

Degree of protection (IP)	X4
Insulation class	F
Installation position	vertical/horizontal
Housing material	sheet steel, powder coated
Weight	11.8kg
Nominal size	355mm
Airstream temperature at I_{MAX}	40°C
EAN	4012799808701

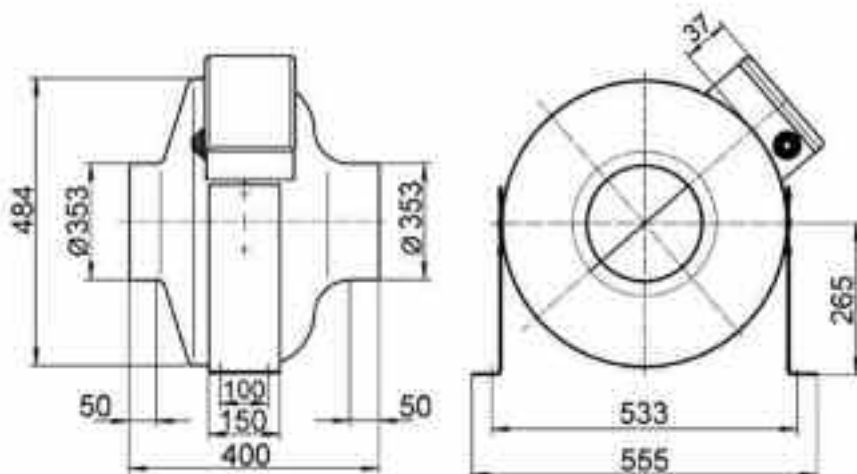

Application examples

- Machine extraction unit
- Workplace air extraction system
- Production site
- Storage facility
- Laboratory

Accessories for ERR 35/1

Shutter	AS 35
Automatic backflow preventer	AVM 35
External grille	MLA 35
External grille	MLZ 35
Internal grilles	LGA, LGZ
Disk valves, synthetic material	TK
Disk valves, metal	TM
Disk valves, fire protection	TB, WBV
Tubular sound absorber	RSR 35/50
Heat exchanger	WT 3000
Electrical air heater with controller	DRH 35-12 R
Water air heater	WRH 40-9
Fixing cuff	ELR 35
Mounting foot	FUR 35/1
Air filter	TFE 35-4
Air filter	TFE 35-5
Air filter	TFE 35-7
Speed controller	ST 2,5
Speed controller, distribution board	STS 2,5
5-step transformer	TRE 1,6
5-step transformer, control cabinet	TRE 1,6 S
5-step switch for 5-step transformer	ESS 20

Performance Curve ERR 35/1S

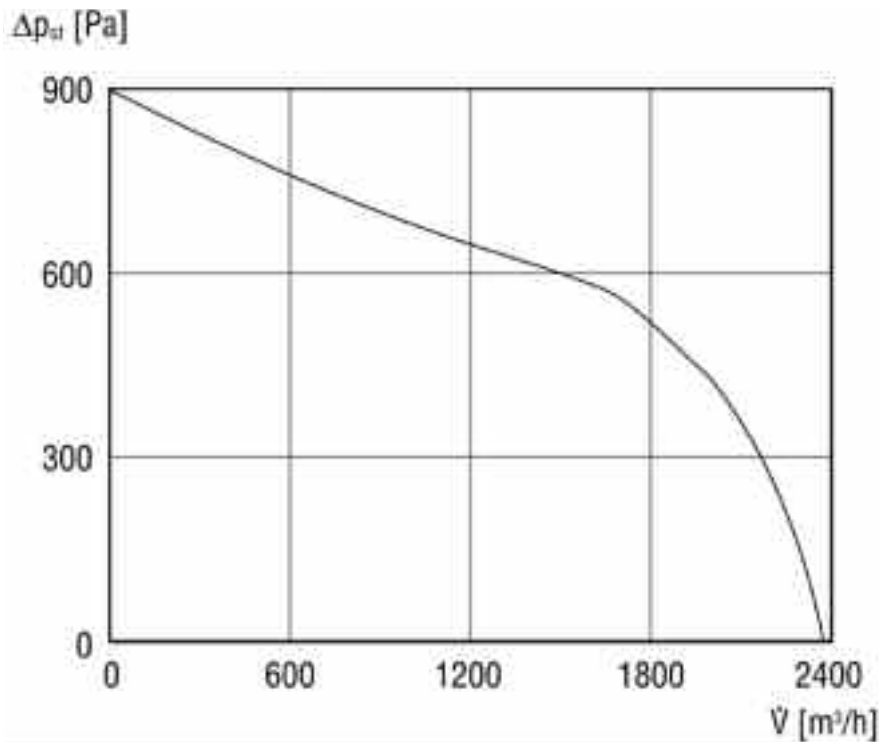

Technical data

Air flow volume	2350m³/h	Degree of protection (IP)	X4
Rotating speed	2350 1/min	Insulation class	F
Speed controllable	Yes	Installation position	vertical/horizontal
Type of voltage	Alternating current	Housing material	sheet steel, powder coated
Rated voltage	230 V	Weight	14.1kg
Power frequency	50 Hz	Nominal size	355mm
Nominal output	630W	Airstream temperature at I_{MAX}	40°C
I_{MAX}	2.82A	EAN	4012799808718



Application examples

- Machine extraction unit
- Workplace air extraction system
- Production site
- Storage facility
- Laboratory

Accessories for ERR 35/1S

Shutter	AS 35
Automatic backflow preventer	AVM 35
External grille	MLA 35
External grille	MLZ 35
Internal grilles	LGA, LGZ
Disk valves, synthetic material	TK
Disk valves, metal	TM
Disk valves, fire protection	TB, WBV
Tubular sound absorber	RSR 35/50
Heat exchanger	WT 3000
Electrical air heater with controller	DRH 35-12 R
Water air heater	WRH 40-9
Fixing cuff	ELR 35
Mounting foot	FUR 35/1
Air filter	TFE 35-4
Air filter	TFE 35-5
Air filter	TFE 35-7
Speed controller	ST 5
Speed controller, distribution board	STS 2,5
5-step transformer	TRE 3,3
5-step transformer, control cabinet	TRE 1,6 S
5-step switch for 5-step transformer	ESS 20

