

Moduflow Fan Type A

Specification

The Moduflow range of variable discharge centrifugal fans are constructed with a rigid 2mm and 1.5mm galvanised steel case. The cases are fitted with circular spigot inlets, to accept standard spiral ducting. The discharge flange is pre-drilled to accept rectangular ducting. They are fitted with backward curved impellers and external rotor motors, for 100% speed control. Sealed for life bearing, class F insulation, and fitted with thermal cutout.



Features

- Can be fitted on top, bottom, horizontal or vertical discharges without having to adjust the fan assembly bolts
- Inlet spigots on all fans match standard spiral ducts
- External rotor motor drive offers space saving within a compact design
- Ideal for application where system resistance is high
- External rotor motors have low starting currents
- 100% speed controllable by voltage regulation
- Ideal for handling light dust
- Ideal for high system losses
- Class F insulation IP54 rating
- Suitable for atmospheres up to 95% RH and temperature up to 70°C

Moduflow Fan Type A Backward Curved Centrifugal Fan. Product Installation & Maintenance Instructions.

Moduflow Type A Fans

The Backward Curved Centrifugal Range of fans consists of 7 duty sizes with a maximum air flow of 4.7 m³/s.

The units are manufactured from galvanised sheet steel to BS. 2989. 1982.

All units can be mounted top, bottom, horizontal or vertical discharges without having to adjust the fan assembly bolts.

Handling

Always handle the units carefully to avoid damage and distortion.

Care must be taken to ensure that any slings used for hoisting do not damage the casing.

Fan Installation

Installation must be completed by competent persons, in accordance with good industry practice and should conform to all governing and statutory bodies i.e. IEE, CIBSE, COHSE etc.

The unit can be installed at any upward vertical or horizontal position and is suitable for internal or external use.

Elongated mounting slots are provided on 3 sides of the unit for either bolting directly to the mounting surface or via anti-vibration mounts.

The method chosen is the responsibility of the installer.

Electrical

Check that the fan details on the rating plate correspond with the supply voltage and frequency. Motors are designed for Direct on-line starting. Motor overloads should be set to the full load current on the fan rating label. Supply fuses should be H.R.C. type.

Start-up Procedure

Note! The single phase rotational direction is set at works and should NOT be altered. For 3 phase units check that rotation is correct, if not interchange 2 phases. Equipment should be run for approximately 30 minutes to ensure correct operation. If a fault occurs, switch off. Do NOT restart until fault has been rectified.

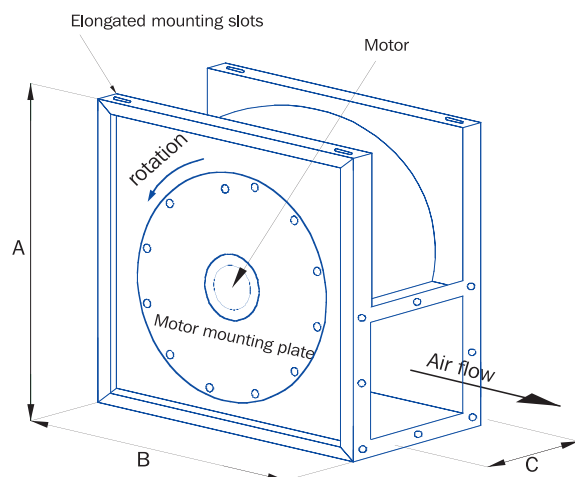

WIRING DIAGRAM No. 01.024
Single phase AC motor with operating capacitor and thermal contacts. Thermal contact wired in series with windings.

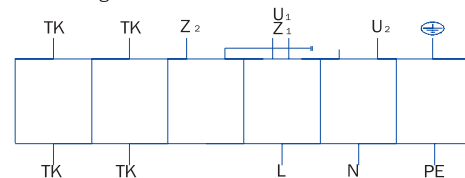

- KEY
- U1 - BROWN
 - U2 - BLUE
 - Z1 - BLACK
 - Z2 - ORANGE
 - TK - WHITE
 - PE - YELLOW/GREEN

WIRING DIAGRAM No. 01.006
3 phase motor in delta connection with thermal contacts. Changing of rotation direction by interchanging of two phases

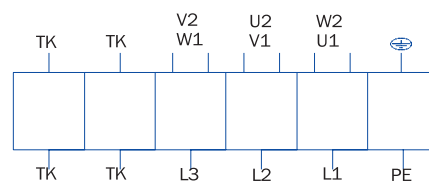

- KEY
- U1 - BROWN
 - V1 - BLUE
 - W1 - BLACK
 - U2 - RED
 - V2 - GREY
 - W2 - ORANGE
 - TK - WHITE
 - PE - YELLOW/GREEN

Motor / Fan details

Unit	Phase	Watts	flc	sc	Nom'l rpm	max temp	A	B	C
1-315/1.A	1	170	0.75	1.20	1200	40 c	610	568	225
2-350/1.A	1	320	1.40	2.80	1300	40 c	690	650	250
3-400/1.A	1	580	2.80	6.16	1340	40 c	790	684	281
4-450/1.A	1	840	3.70	7.77	1210	40 c	867	770	318
5-500/3.A	3	1800	3.50	14.0	1380	40 c	950	865	359
6-560/3.A	3	3100	5.50	27.5	1410	40 c	1040	940	397
7-630/3.A	3	4000	6.90	27.6	1340	40 c	1257	1120	399

Maintenance

Electrically isolate before commencing work. Remove motor mounting plate and withdraw impeller assembly. Carefully clean rotating parts and check for damage and security of components. The motor is fitted with sealed-for-life bearings and does not require any further lubrication. Refit motor mounting plate.

One year Warranty

The 1 year warranty starts from the day of delivery and includes parts and labour for the first year. This warranty is conditional on maintenance being carried out 3 months after commissioning.



Performance

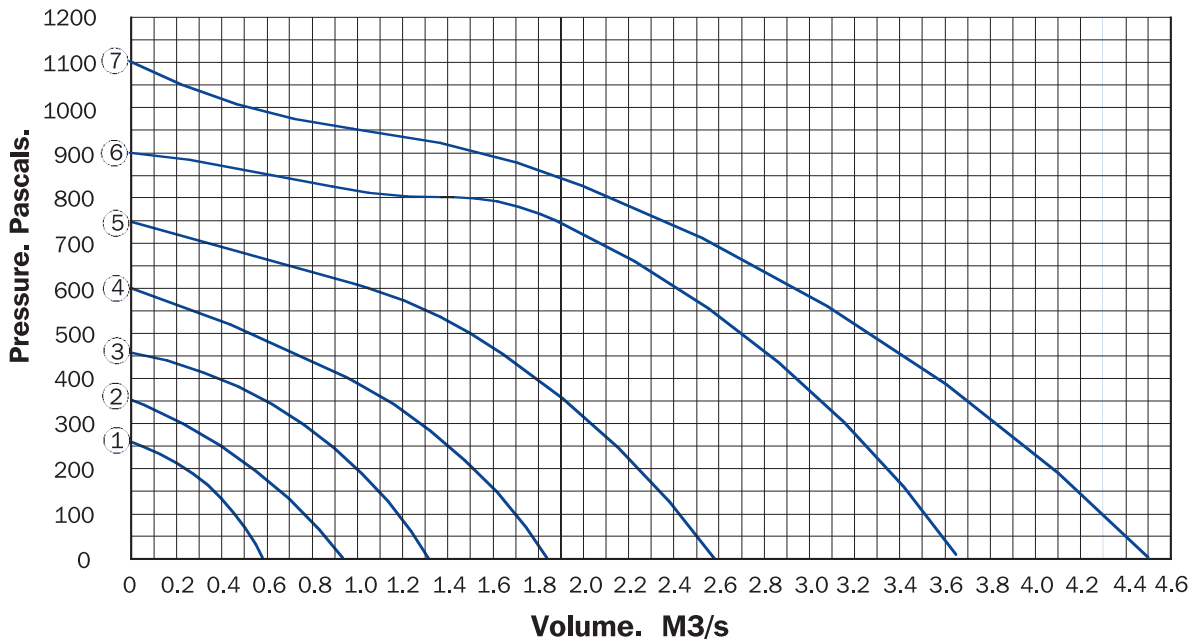

Dimensions in MM

SIZE	A	B	C	D	E	F	G	H	J	K	L	M	O	KW
1 - 315-A	610	568	279	25	344	254	418	40	305	265	225	280	460	0.18
2 - 350-A	690	650	340	25	409	267	500	44	330	290	250	315	540	0.29
3 - 400-A	790	684	375	29	448	305	534	44	361	321	281	350	640	0.54
4 - 450-A	867	770	413	32	489	330	620	44	398	358	318	400	717	0.94
5 - 500-A	950	865	457	37	538	362	715	44	439	399	359	450	800	1.8
6 - 560-A	1040	940	498	41	583	394	790	44	430	437	397	500	890	3.1
7 - 630-A	1257	1120	565	51	660	470	970	44	479	439	399	560	1107	4.0

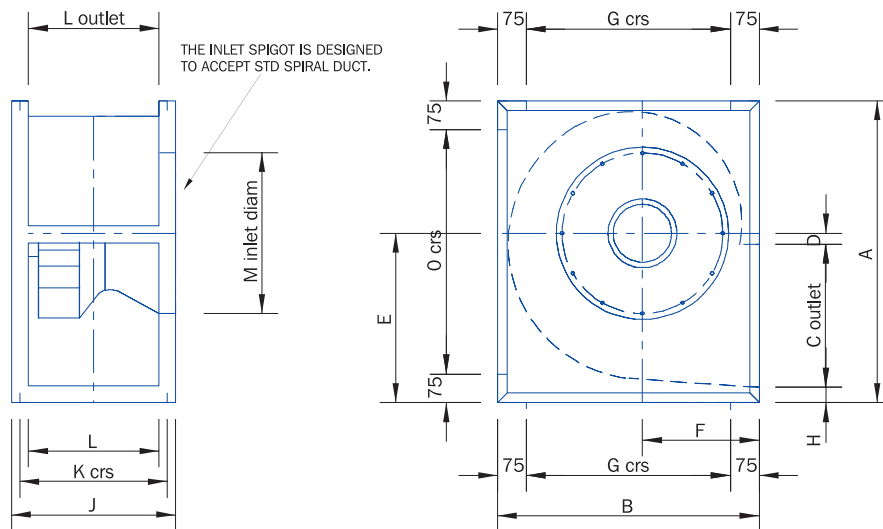

EC DECLARATION OF INCORPORATION FOR PARTY COMPLETED MACHINERY. (MACHINERY DIRECTIVE 2006/42/EC, ANNEX III.B)

Manufacturer: Moduflow Fan Systems Ltd.
Scarth Road
Sowerby Woods Industrial Estate
Barrow-in-Furness
Cumbria LA14 4RF

Type of Machinery: Fan used for moving air or other gases.

Model: MODUFLOW FAN TYPE A

Manufacturer's Ref / Serial No:

I hereby declare that the Essential Health and Safety Requirements of Directive 2006/42/EC that are listed in Annex 1 of this Declaration are applied and fulfilled and that the relevant technical documentation is compiled in accordance with part B of Annex VII of the Directive.

Relevant information on the party completed machinery will be supplied electronically or by post, without prejudice to the intellectual property rights of the manufacturer, in response to a reasoned request by the national authorities.

I furthermore declare that fans manufactured by Moduflow Fan Systems Ltd. are driven by AC induction motors and are inherently compliant with the requirements of the Electromagnetic Compatibility Directive (2004/108/EEC) if supplied with a truly sinusoidal AC supply. Where the fan motor is supplied via a frequency converter or other electronic control, verification of compatibility together with cabling should be sought from the control supplier.

This partly completed machinery must not be put into service until the final machinery or installation into which it is to be incorporated has been declared in conformity with the provisions of Directive 2006/42/EC, where appropriate.

Manufacturer's Representative: R P Whitworth. Position: Director

Signature: Date:

ANNEX I (EC DECLARATION OF INCORPORATION FOR PARTY COMPLETED MACHINERY)

Essential health and safety requirements relating to the design and construction of the Party Completed Machinery.

The following Essential Health and Safety Requirements of Directive 2006/42/EC Annex 1.1, are applied and fulfilled as appropriate:

- 1.1.3 Materials and products
- 1.1.5 Design of machinery to facilitate its handling
- 1.3.1 Risk of loss of stability
- 1.3.2 Risk of break-up during operation
- 1.3.4 Risk due to surfaces, edges or angles
- 1.3.6 Risk related to variations in operating conditions
- 1.5.1 Risk related to electricity supply
- 1.5.4 Errors of fitting
- 1.5.6 Fire
- 1.5.7 Explosion
- 1.5.9 Vibrations
- 1.5.10 Radiation
- 1.5.11 External radiation
- 1.5.13 Emissions of hazardous materials and substances
- 1.6.4 Operator intervention
- 1.7.1 Information and warnings on the machinery
- 1.7.3 Marking of machinery (as appropriate without CE mark)
- 1.7.4 Instructions
 - 1.7.4.1 General principles for the drafting of instructions
 - 1.7.4.2 Contents of the instructions
 - 1.7.4.3 Sales literature

Presumption of conformity with the above listed EHSRs is by application of relevant parts of the following standards:

Applied harmonized standards in particular:
EN ISO 12100-1:2003+A1:2009, EN ISO 12100-2:2003+A1:2009, EN 60204-1:2006+A1:2009, EN ISO 5801:2008 (BS 848-1:2007).

Applied national standards in particular:
BS 848-2.1:2004 (BS ISO 13347-1:2004), BS 848-6:2003 (BS ISO 14695:2003), BS 848-7:2003 (ISO 14694:2003).

INFORMATION FOR SAFE INSTALLATION, OPERATION AND MAINTENANCE OF MODUFLOW LTD VENTILATION EQUIPMENT

To comply with EC Council Directives 2006/42/EC Machinery Directive.
To be read in conjunction with the relevant Product Documentation [see 2.1]

1.0 GENERAL

1.1 The equipment referred to in this Declaration of Incorporation is supplied by Moduflow Ltd to be assembled into a ventilation system which may or may not include additional components.

The entire system must be considered for safety purposes and it is the responsibility of the installer to ensure that all the equipment is installed in compliance with the manufacturers recommendations and with due regard to current legislation and codes of practice.

2.0 INFORMATION SUPPLIED WITH THE EQUIPMENT

2.1 Each item of equipment is supplied with a set of documents which provides the information required for safe installation and maintenance of the equipment. This may be in the form of a Data sheet and/or Installation and Maintenance instruction.

2.2 Each unit has a rating plate attached to its outer casing. The rating plate contains essential data relating to the equipment such as serial number, unit code and electrical data. Any further data that may be required will be found in the documentation. If any item is unclear or more information is required, contact Saverfan.

2.3 Where warning labels or notices are attached to the unit, the instructions given must be adhered to.

3.0 TRANSPORTATION, HANDLING AND STORAGE.

3.1 Care must be taken at all times to prevent damage to the equipment. Note that shock to the unit may result in the balance of the impeller being affected.

3.2 When handling the equipment, care should be taken with corners and edges and that the weight distribution within the unit is considered. Lifting gear such as slings or ropes must be arranged so as not to bear on the casing or impeller/motor.

3.3 Equipment stored on site prior to installation should be protected from the weather and steps taken to prevent the ingress of contaminants.

4.0 OPERATIONAL LIMITS

4.1 It is important that the specified operation limits for the equipment are adhered to e.g. operation air temperatures, air borne contaminants and unit operation.

4.2 Where installation accessories are supplied with the specified equipment e.g. wall mounting brackets or anti-vibration mounts, they are to be used to support the equipment only. Other system components must have separate provision for support.

4.3 Flanges and connection spigots are provided for the purpose of joining to ductwork systems. They must not be used to support the ductwork.

5.0 INSTALLATION REQUIREMENTS

In addition to the particular requirements given for the individual product, the following general requirements should be noted.

5.1 Where access to any part of equipment which moves, or can become electrically live are not prevented by the equipment panels or by fixed installation detail [e.g ducting], then guarding to the appropriate standard must be fitted.

5.2 The electrical installation of the equipment must comply with the requirements of the relevant local electrical standards.

6.0 COMMISSIONING REQUIREMENTS

6.1 General pre-commissioning checks relevant to safe operation consist of the following:

Ensure that no foreign bodies are present within the fan or casing.

Check electrical safety, eg. Insulation and earthing.

Check guarding of system.

Check operation of Isolators/controls.

Check fastenings for security.

6.2 Other commissioning requirements are given in the relevant product documentation.

7.0 OPERATIONAL REQUIREMENTS

7.1 Equipment access panels must be in place at all times during operation of the unit and must be secured with the original fastenings.

7.2 If failure of equipment occurs or is suspected then it should be taken out of service until a competent person can effect repair or examination. [Note that certain ranges of equipment are designed to detect and compensate for fan failure].

8.0 MAINTENANCE REQUIREMENTS

8.1 Specific maintenance requirements are given in the relevant documentation.

8.2 It is important that the correct tools are used for the various tasks required.

8.3 If the access panels are to be removed for any reason the electrical supply to the unit must be isolated.

8.4 A minimum period of 2 minutes should be allowed after electrical disconnection before access panels are removed. This will allow the impeller to come to rest.

NB: Care should still be taken however since airflow generated at some other point in the system can cause the impeller to 'windmill'.

8.5 Care should be taken when removing and storing access panels in windy conditions.